

## Operating Instructions

### Top Loaders

### Top ..., HO ..., F ...

M01.0062 ENGLISCH

Original instructions

■ Made  
■ in  
■ Germany

[www.nabertherm.com](http://www.nabertherm.com)

---

### **Copyright**

© Copyright by  
Nabertherm GmbH  
Bahnhofstrasse 20  
28865 Lilienthal  
Federal Republic of Germany

Reg: M01.0062 ENGLISCH  
Rev: 2017-05

No responsibility is accepted for the correctness of this information. We reserve the right to make technical alterations.

|          |  |           |
|----------|--|-----------|
| <b>1</b> | <b>Introduction .....</b>  | <b>5</b>  |
| 1.1      | Product Description.....   | 6         |
| 1.2      | Overview of the Complete Furnace.....                                    | 7         |
| 1.2.1    | Key to the Model Names .....   | 9         |
| 1.3      | Scope of Delivery.....   | 9         |
| <b>2</b> | <b>Specifications .....</b>  | <b>10</b> |
| 2.1      | Warranty and Liability .....   | 13        |
| <b>3</b> | <b>Safety .....</b>  | <b>14</b> |
| 3.1      | Explanation of the Symbols and Warnings .....                            | 14        |
| 3.2      | Defined Application .....  | 17        |
| 3.3      | Requirements for the Furnace Operator .....                              | 18        |
| 3.4      | Protective Clothing.....   | 19        |
| 3.5      | Basic Measures During Normal Operation .....                             | 20        |
| 3.6      | Basic Measures in Case of Emergency .....                                | 20        |
| 3.6.1    | What to Do in an Emergency .....   | 20        |
| 3.7      | Basic Measures for Servicing and Maintenance.....                        | 21        |
| 3.8      | General Risks with the Furnace.....                                      | 22        |
| <b>4</b> | <b>Transportation, Installation and Initial Start-Up.....</b>            | <b>23</b> |
| 4.1      | Delivery.....  | 23        |
| 4.2      | Unpacking .....  | 24        |
| 4.3      | Transport Securing Device/Packaging .....                                | 26        |
| 4.4      | Constructional and Connection Requirements .....                         | 26        |
| 4.4.1    | Installation (Furnace Location).....                                     | 26        |
| 4.5      | Assembly, Installation, and Connection .....                             | 28        |
| 4.5.1    | Assembling the Base Extension (Accessory).....                           | 28        |
| 4.5.2    | Assembling the Castors.....  | 29        |
| 4.5.3    | Assembling the Controller (Depending on the Model) .....                 | 31        |
| 4.5.4    | Place the Controller in the Holder on the Furnace (model-related) .....  | 32        |
| 4.5.5    | Assembling the Bypass Connection.....                                    | 32        |
| 4.5.6    | Venting Exhaust Fumes .....  | 33        |
| 4.5.7    | Connecting the Furnace to the Power Supply .....                         | 36        |
| 4.6      | Initial Start-Up .....   | 37        |
| 4.7      | Recommendations for Heating Up the Furnace for the First Time .....      | 38        |
| <b>5</b> | <b>Operation .....</b>   | <b>39</b> |
| 5.1      | Controller .....   | 39        |
| <b>6</b> | <b>Operation, Display and Switch Elements (depending on design).....</b> | <b>40</b> |
| 6.1      | Turning on the Controller/Furnace.....                                   | 40        |
| 6.2      | Turning off the Controller/Furnace .....                                 | 40        |
| 6.2.1    | Handling the Controller .....  | 40        |
| 6.3      | Opening and Closing the Lid .....  | 41        |
| 6.4      | Fresh Air Valve .....  | 43        |
| 6.5      | Loading/Charging .....   | 43        |
| 6.5.1    | Tips for Potters.....  | 44        |
| 6.5.1.1  | Preset programs for ceramic applications .....                           | 44        |
| 6.5.2    | Bisque Firing.....   | 47        |

---

|           |   |           |
|-----------|---|-----------|
| 6.5.3     | Glaze Firing .....  | 47        |
| 6.5.4     | Reduction Firing .....  | 48        |
| <b>7</b>  | <b>Servicing, Cleaning, and Maintenance .....</b>                       | <b>48</b> |
| 7.1       | Shutting Down the Furnace for Servicing, Cleaning, and Maintenance..... | 48        |
| 7.2       | Furnace Insulation .....  | 48        |
| 7.3       | Regular Maintenance of the Furnace.....                                 | 49        |
| 7.4       | Adjusting the Lid.....  | 50        |
| 7.5       | Adjusting the Tensioning Straps .....                                   | 52        |
| 7.6       | Separate the Snap-In Coupling (Plug) from the Furnace Housing .....     | 52        |
| 7.7       | Cleaning Products .....   | 53        |
| <b>8</b>  | <b>Malfunctions .....</b>   | <b>53</b> |
| 8.1       | Error Messages of the Controller .....                                  | 54        |
| 8.2       | Warnings of the Controller.....   | 56        |
| 8.3       | Malfunctions of the Switchgear .....                                    | 58        |
| 8.4       | Controller Check List .....   | 59        |
| <b>9</b>  | <b>Spare Parts/Wearing Parts.....</b>                                   | <b>61</b> |
| 9.1       | Replacing a Heating Element.....  | 61        |
| 9.2       | Replacing a Thermocouple.....   | 70        |
| <b>10</b> | <b>Accessories (Options) .....</b>                                      | <b>72</b> |
| <b>11</b> | <b>Electrical Connection (Circuit Diagram) .....</b>                    | <b>73</b> |
| <b>12</b> | <b>Nabertherm Service.....</b>  | <b>73</b> |
| <b>13</b> | <b>Shut-Down, Dismantling, and Storage.....</b>                         | <b>74</b> |
| 13.1      | Environmental Regulations .....   | 74        |
| 13.2      | Transportation/Return Transportation.....                               | 75        |
| <b>14</b> | <b>Declaration of Conformity .....</b>                                  | <b>76</b> |
| <b>15</b> | <b>For Your Notes .....</b>   | <b>77</b> |

## 1 Introduction

### Dear Customer,

Thank you for choosing a quality product from Nabertherm GmbH.

You can be proud that you have chosen a furnace which has been especially tailored to suit your manufacturing and production conditions.

This product is characterized by

- professional workmanship
- high performance due to its high efficiency
- high-quality insulation
- low power consumption
- low noise level
- simple installation
- easy to maintain
- high availability of spare parts

Your Nabertherm Team



#### Note

These documents are intended only for buyers of our products and may not be copied or disclosed to third parties without our written consent. (Law governing copyright and associated protective rights, German Copyright Law from Sept. 9, 1965)

#### Protective Rights

Nabertherm GmbH owns all rights to drawings, other documents and authorizations, also in case of applications for protective rights.



#### Note

All the figures in the instructions have a descriptive character; in other words, they do not represent the exact details of the furnace.



#### Note

The pictures contained in the instruction manual may contain inaccuracies in terms of the function, design and furnace model.

---

## 1.1 Product Description

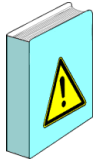

These electrically heated furnaces are a high-quality product which will give you many years of reliable service if they are properly cared for and maintained. One basic prerequisite is that the furnace is used the way it was designed to be used.

During development and production a high priority was placed on safety, functionality and economy.

Furnaces in the **Top loader Top ...**, **Top loader HO ...** and **Fusing top loader F ...** series are electrically heated furnaces for ceramics, glass fusing, glass and porcelain painting. These furnace models have an appealing design, are lightweight and produce good firing results. The right furnace for hobby artists or small workshops.

### Other Characteristics of this Product are:

- Heating elements embedded in grooves, heating from all sides
- Top-quality heating elements, optimum wire gauge and length for long life
- Solid state relays provide for low-noise heater operation
- Rapid switching cycles result in precise temperature control
- Type S thermocouple
- Lid interlock safety switch
- Multi-layered insulation for low power consumption and low exterior temperatures
- Models Top 60eco ff. with special high-grade, energy-saving backing insulation
- Lightweight refractory bricks inside furnace chamber for clean firing results
- Housing made of sheets of textured stainless steel
- Lid with adjustable quick-release lock and padlock hasp
- Lid heating for direct radiation of the charge (fusing top loaders F 30 – F 220)
- Wear-free lid seal (brick on brick)
- Powerful gas dampers make lid opening very easy
- Infinitely adjustable air inlet in opening in the furnace bottom for good ventilation and short cooling times
- Exhaust air outlet on furnace side with stub for pipe of diameter 80 mm
- Lockable castors for easy transport of furnace without the need for lifting

### Additional Equipment

- Bottom heating for very good temperature uniformity for Top 140 and Top 190
- Two-zone control of heating via controller
- Raised base for Top 45/ Top 60 and F 75/F 110

## 1.2 Overview of the Complete Furnace

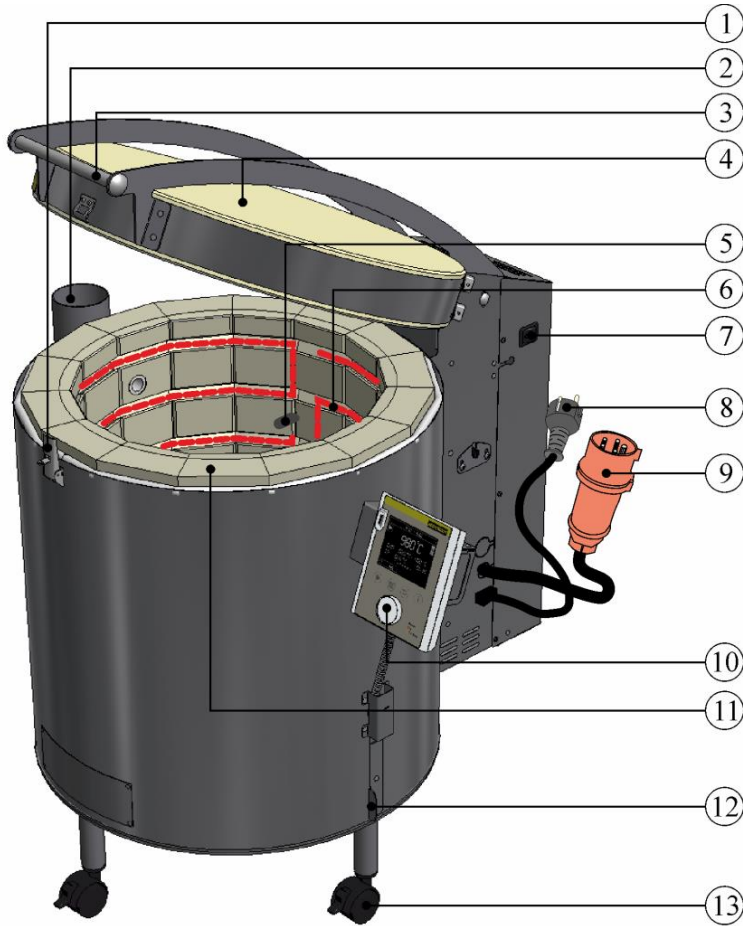

Example: Top loader model Top 60

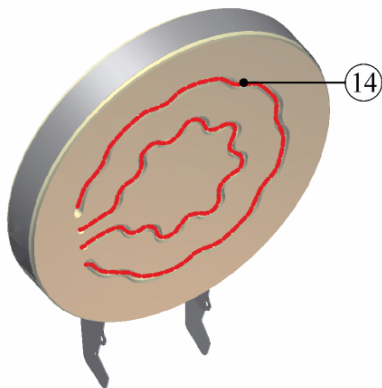

Example: Lid from the fusing top loader Model F 30



Example: Fusing top loader Model F 220

Fig. 1: Example: Top loader model Top ... and Fusing top loader Model F ... (similar to picture)

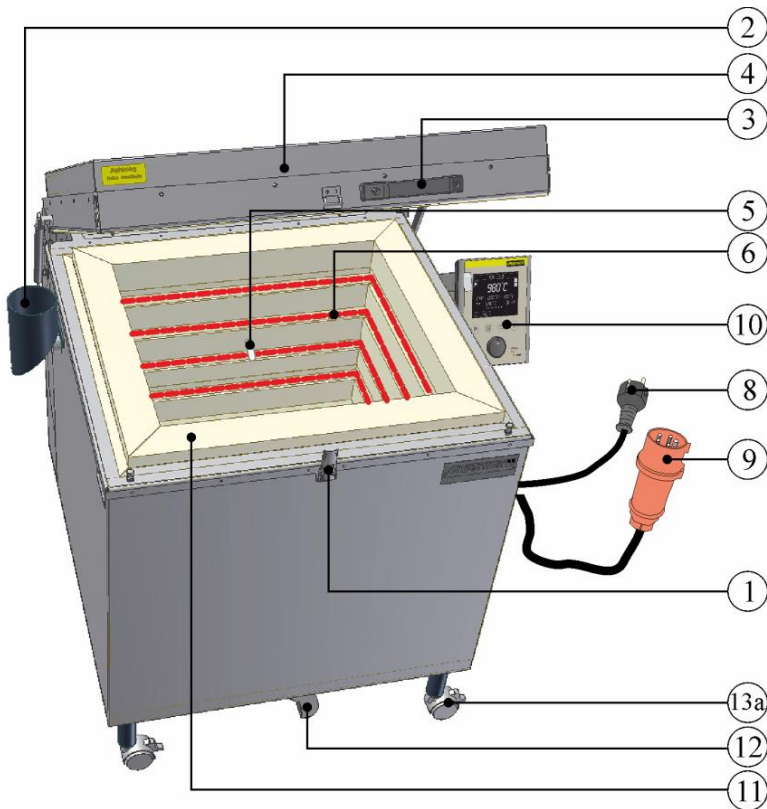

Fig. 2: Example: Top loader Model HO 100 (similar to picture)

| No. | Designation   |
|-----|---|
| 1   | Adjustable lid closure                                |
| 2   | Bypass connection (Top + HO model only)               |
| 3   | Handle  |
| 4   | Lid   |
| 5   | Thermocouple  |
| 6   | Heating element                                       |
| 7   | Power switch (to switch the furnace on and off)       |
| 8   | Power plug (up to 3600 watts)                         |
| 9   | Power plug (from 5500 watts)                          |
| 10  | Controller  |
| 11  | Insulation  |
| 12  | Supply air valve                                      |
| 13  | Castor with locking brake                             |
| 13a | Castor (with locking brake from Model HO 70 + HO 100) |
| 14  | Lid heating (Fusing top loader F ...)                 |



| No. | Designation  |
|-----|--|
| 15  | Base frame (Model Top 220/Fusing top loader from Model F 75) |

### 1.2.1 Key to the Model Names

| Example             | Explanation  |
|---------------------|--|
| Top 60/Leco         | <b>Top</b> = Top loader, round/oval<br><b>HO</b> = Top loader, rectangular<br><b>F</b> = Fusing top loader |
| Top <b>60</b> /Leco | <b>X</b> = Liters furnace chamber (volume in liters)   |
| Top 60/Leco         | <b>L</b> = low<br><b>LE</b> = low energy<br><b>R</b> = rapid   |
| Top 60/Leco         | <b>eco</b> = economy   |



| <br>Nabertherm GmbH<br>Bahnhofstr. 20, 28865 Lilienthal/Bremen, Germany<br>Tel +49 (04298) 922-0, Fax +49 (04298) 922-129<br>contact@nabertherm.de<br>www.nabertherm.com |                  |        |
|--|------------------|--------|
| Top 160  | SN 123456        | 2017   |
| TOP1603BN1   | 1320 °C          | -      |
| -  | 400 V 3/N/PE~    | -      |
| 50/60 Hz   | 13,0/13,0/13,0 A | 9,0 kW |

Made in Germany

Fig. 3: Example: Model name (type plate)

### 1.3 Scope of Delivery

The scope of delivery includes:

|  | Furnace components   | Quantity              | Comment         |
|--|--|-----------------------|-----------------|
|  | <b>-Furnace model Top ...,</b><br><b>-Furnace model HO ... or</b><br><b>-Furnace model F ...</b> | 1 x                   | Nabertherm GmbH |
|  | Power cable <sup>1)</sup>  | 1 x                   | Nabertherm GmbH |
|  | Bypass connection <sup>1)</sup><br>(for furnace models Top and HO)                               | 1 x                   | Nabertherm GmbH |
|  | Ceramic shelves<br>(691600956 – 80x80x10 mm)   | 3 x                   | Nabertherm GmbH |
|  | Castors  | 4 to 6x <sup>3)</sup> | Nabertherm GmbH |
|  | Hex key <sup>1)</sup><br>(for furnace models Top and F)  | 1 x                   | Nabertherm GmbH |

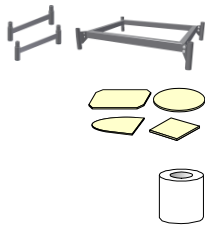

| Furnace components   | Quantity | Comment                    |
|--|----------|----------------------------|
| <b>Accessories:</b>  |          |                            |
| Adjustable base <sup>1)</sup> (for furnace models Top 45/60 or F 75/F 110) | 1 x      | Nabertherm GmbH            |
| Shelve/s <sup>2)</sup> for furnace models Top, HO and F                    | 4)       | Nabertherm GmbH            |
| Props <sup>2)</sup>  | 4)       | Nabertherm GmbH            |
| Other components, variable depending on the particular furnace             | - - -    | See the shipping documents |



| Document type   | Quantity | Comment         |
|---|----------|-----------------|
| Furnace operating manual                                      | 1 x      | Nabertherm GmbH |
| Controller operating manual                                   | 1 x      | Nabertherm GmbH |
| Other documents, variable depending on the particular furnace | - - -    |                 |

- 1) in delivery scope depending on the design/furnace model
- 2) in delivery scope as required, see shipping documents
- 3) quantity depends on furnace model
- 4) quantity as required, see shipping documents



**Note**

Store all documents carefully. All the functions of this furnace were tested during manufacturing and prior to shipping.



**Note**

The documents included do not always contain the electrical schematics and pneumatic diagrams.  
If you need the respective diagrams, they can be ordered from Nabertherm Service.

## 2 Specifications



Electrical specifications are on the type plate located on the side of the furnace.

### Furnace model Top

| Model     | Tmax<br>°C | Inner dimensions in mm |     | Volume<br>in l | Outer dimensions in mm |     |     | Connected load<br>kW | Electrical connection | Weight<br>in kg |
|-----------|------------|------------------------|-----|----------------|------------------------|-----|-----|----------------------|-----------------------|-----------------|
|           |            | w                      | d   |                | h                      | W   | D   |                      |                       |                 |
| Top 16/R  | 1320       | Ø 290                  | 230 | 16             | 440                    | 650 | 530 | 2.6                  | 1-phase               | 32              |
| Top 45eco | 1320       | Ø 410                  | 340 | 45             | 580                    | 880 | 760 | 2.9                  | 1-phase               | 62              |
| Top 45    | 1320       | Ø 410                  | 340 | 45             | 580                    | 880 | 760 | 3.6                  | 1-phase               | 62              |
| Top 45/R  | 1320       | Ø 410                  | 340 | 45             | 580                    | 880 | 760 | 5.5                  | 3-phase <sup>1</sup>  | 62              |
| Top 60    | 1200       | Ø 410                  | 460 | 60             | 580                    | 870 | 870 | 3.6                  | 1-phase               | 72              |

| Model      | Tmax<br>°C | Inner dimensions in<br>mm |     |     | Volume<br>in l | Outer dimensions in<br>mm |      |      | Connected<br>load<br>kW | Electrical<br>connection | Weight<br>in kg |
|------------|------------|---------------------------|-----|-----|----------------|---------------------------|------|------|-------------------------|--------------------------|-----------------|
|            |            | w                         | d   | h   |                | W                         | D    | H    |                         |                          |                 |
| Top 60Leco | 1200       | Ø 410                     |     |     | 60             | 580                       | 870  | 870  | 2.9                     | 1-phase                  | 72              |
| Top 60eco  | 1320       | Ø 410                     |     |     | 60             | 580                       | 870  | 870  | 3.6                     | 1-phase                  | 72              |
| Top 60/R   | 1320       | Ø 410                     |     |     | 60             | 580                       | 870  | 870  | 5.5                     | 3-phase <sup>1</sup>     | 72              |
| Top 80     | 1320       | Ø 480                     |     |     | 80             | 660                       | 950  | 890  | 5.5                     | 3-phase <sup>1</sup>     | 100             |
| Top 100 LE | 1320       | Ø 480                     |     |     | 100            | 660                       | 970  | 1000 | 6.0                     | 1-phase <sup>2</sup>     | 102             |
| Top 100    | 1320       | Ø 480                     |     |     | 100            | 660                       | 970  | 1000 | 7.0                     | 3-phase                  | 102             |
| Top 130    | 1320       | Ø 590                     |     |     | 130            | 770                       | 1090 | 920  | 9.0                     | 3-phase                  | 110             |
| Top 140 LE | 1320       | Ø 550                     |     |     | 140            | 730                       | 1040 | 1020 | 6.0                     | 1-phase <sup>2</sup>     | 124             |
| Top 140    | 1320       | Ø 550                     |     |     | 140            | 730                       | 1040 | 1020 | 9.0                     | 3-phase                  | 124             |
| Top 160    | 1320       | Ø 590                     |     |     | 160            | 770                       | 1090 | 1030 | 9.0                     | 3-phase                  | 130             |
| Top 190    | 1320       | Ø 590                     |     |     | 190            | 770                       | 1090 | 1150 | 11.0                    | 3-phase                  | 146             |
| Top 220    | 1320       | 930                       | 590 | 460 | 220            | 1100                      | 1030 | 930  | 15.0                    | 3-phase                  | 150             |

<sup>1</sup>Heating only between two phases  
<sup>2</sup>Fusing of 32 A if connected to 230 V

**Furnace model F**

| Model    | Tmax<br>°C | Inner dimensions in<br>mm |     |     | Floor<br>space<br>in m <sup>2</sup> | Outer dimensions in<br>mm |     |     | Connected<br>load<br>kW | Electrical<br>connection | Weight<br>in kg |
|----------|------------|---------------------------|-----|-----|-------------------------------------|---------------------------|-----|-----|-------------------------|--------------------------|-----------------|
|          |            | w                         | d   | h   |                                     | W                         | D   | H   |                         |                          |                 |
| F 30     | 950        | Ø 410                     |     |     | 0.13                                | 650                       | 800 | 500 | 2.0                     | 1-phase                  | 50              |
| F 75 L   | 950        | 750                       | 520 | 230 | 0.33                                | 950                       | 880 | 680 | 3.6                     | 1-phase                  | 80              |
| F 75     | 950        | 750                       | 520 | 230 | 0.33                                | 950                       | 880 | 680 | 5.5                     | 3-phase                  | 80              |
| F 110 LE | 950        | 930                       | 590 | 230 | 0.47                                | 1120                      | 950 | 680 | 6.0                     | 1-phase <sup>1</sup>     | 95              |
| F 110    | 950        | 930                       | 590 | 230 | 0.47                                | 1120                      | 950 | 680 | 7.5                     | 3-phase                  | 95              |
| F 220    | 950        | 930                       | 590 | 460 | 0.47                                | 1120                      | 950 | 910 | 15.0                    | 3-phase                  | 115             |

<sup>1</sup>Fusing of 32 A if connected to 230 V

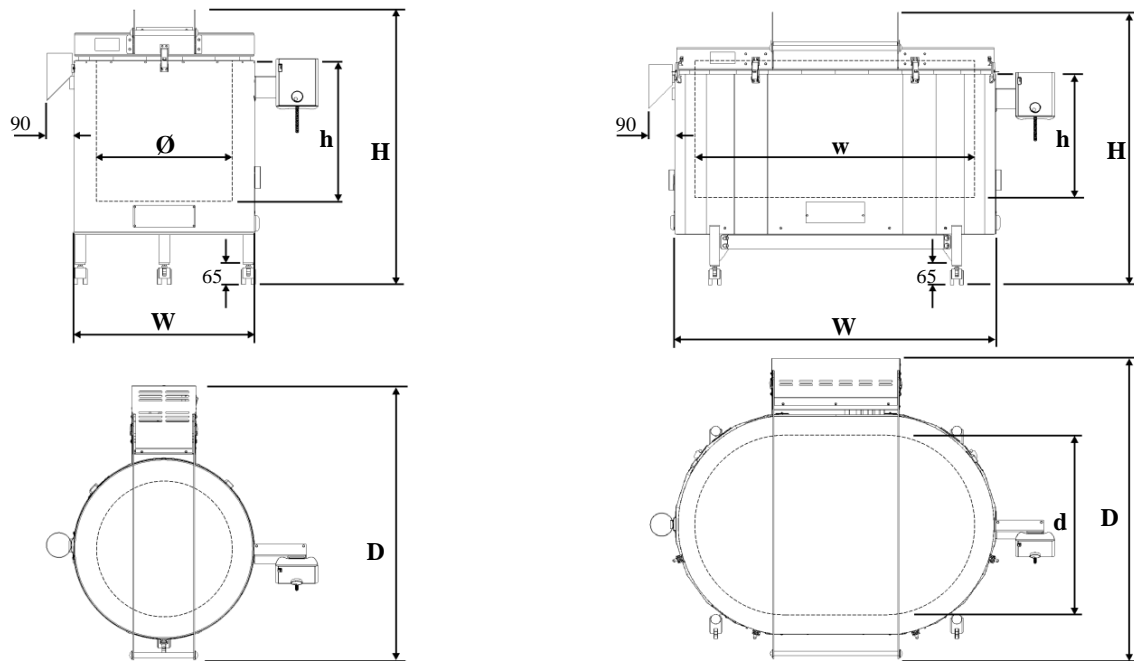

Fig. 4: Top 16 – 190 / F 30

Top 220 / F 75 – F 22

**Furnace model HO**

| Model   | Tmax<br>°C | Inner dimensions in<br>mm |     |     | Volume<br>in l | Outer dimensions in<br>mm |     |     | Connected<br>load<br>kW | Electrical<br>connection | Weight<br>in kg |
|---------|------------|---------------------------|-----|-----|----------------|---------------------------|-----|-----|-------------------------|--------------------------|-----------------|
|         |            | w                         | d   | h   |                | W                         | D   | H   |                         |                          |                 |
| HO 70/L | 1200       | 440                       | 380 | 420 | 70             | 640                       | 770 | 780 | 3.6                     | 1-phase                  | 120             |
| HO 70/R | 1300       | 440                       | 380 | 420 | 70             | 640                       | 770 | 780 | 5.5                     | 3-phase <sup>1</sup>     | 120             |
| HO 100  | 1300       | 480                       | 430 | 490 | 100            | 680                       | 820 | 850 | 5.5                     | 3-phase <sup>1</sup>     | 160             |

<sup>1</sup>Heating only between two phases

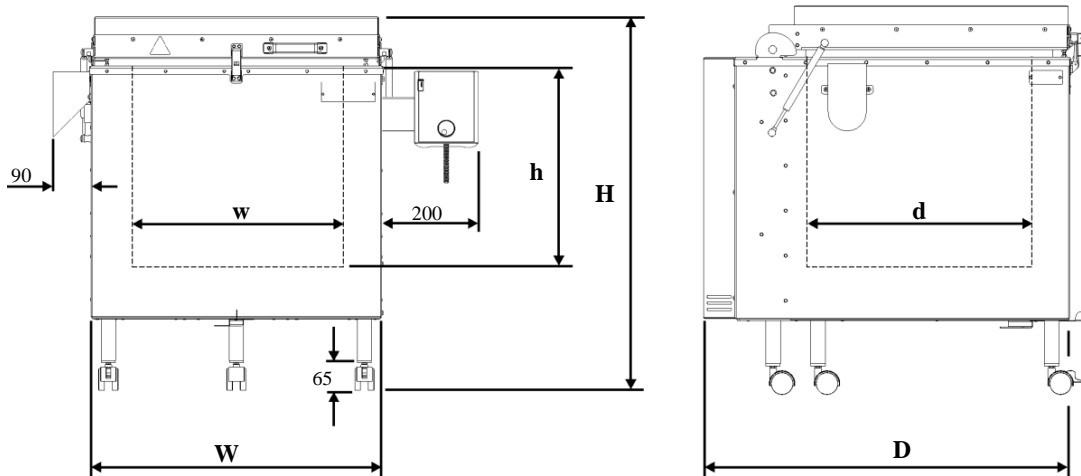

Fig. 5: Dimensions of model HO

| Electrical connection | Voltage (V) | 1-phase:                  | 3-phase: | Special voltage: |
|-----------------------|-------------|---------------------------|----------|------------------|
| Furnace model         |             | See type plate on furnace |          |                  |
|                       | Frequency:  | 50 or 60 Hz               |          |                  |

|  |                                  |  |
|--|----------------------------------|--|
| <b>Thermal protection class</b>                    | Furnaces:                        | <b>according to DIN EN 60519-2</b><br>without safety controller: Class 0<br>(in case of fault, no protection for furnace or charge)<br>with safety controller: Class 2<br>(in case of fault, furnace and charge protected) |
| <b>Protection rating</b>                           | Furnaces:                        | 1  |
| <b>Protection type</b>                             |                                  | IP20   |
| <b>Ambient conditions for electrical equipment</b> | Temperature:                     | +5 °C to +40 °C  |
|  | Humidity:                        | max. 80 % non condensing   |
| <b>Weights</b>                                     | Furnace with accessories         | Varies (see shipping documents)  |
| <b>Emissions</b>                                   | Continuous sound pressure level: | < 80 dB(A)   |

## 2.1 Warranty and Liability



**As regards warranty and liability, the normal Nabertherm warranty terms apply, unless individual terms and conditions have been agreed. However, the following conditions also apply:**

Warranty and liability claims for personal injury or damage to property shall be excluded if they are attributable to one or more of the following causes:

- All persons involved in operation, installation, maintenance, or repair of the furnace must have read and understood the operating instructions. No liability will be accepted for damage or disruption to operation resulting from non-compliance with the operating instructions.
- Not using the furnace as intended
- Improper installation, start-up, operation, or maintenance of the furnace,
- Operation of the furnace with defective safety equipment or improperly installed or non-functioning safety and protective equipment
- Not observing the information in the operating instructions with respect to transportation, storage, installation, start-up, operation, maintenance, or equipping the furnace
- Making unauthorized changes to the furnace
- Making unauthorized changes to the operating parameters
- Making unauthorized changes to the parameterization, the settings, or the program
- Nabertherm accepts absolutely no liability for damage caused by using parts that are not original Nabertherm parts. Original parts and accessories are designed especially for Nabertherm furnaces. Replace parts only with original Nabertherm parts. Otherwise the warranty will be void.
- Catastrophes due to third-party causes and force majeure

### 3 Safety

#### 3.1 Explanation of the Symbols and Warnings



##### Note

In the following operating instructions, specific warnings are given to draw attention to residual risks that cannot be avoided when the furnace is operating. These residual risks include dangers for humans/products/ the furnace, and the environment.

The symbols used in the operating instructions are especially intended to draw attention to safety information.

The symbols used cannot replace the text of the safety information. Therefore, always read the entire text.

Graphic symbols correspond to **ISO 3864**. In accordance with the **American National Standard Institute (ANSI) Z535.6** the following warning information and words are used in this document:



The general hazard symbol, in combination with the words **CAUTION, WARNING** and **DANGER** warns about the risk of serious injury. Observe the following information to prevent injury or death.

##### NOTE

Refers to a hazard that could damage or destroy the equipment.

##### CAUTION

Refers to a hazard with a minor or medium risk of injury.

##### WARNING

Refers to a hazard that could cause death, serious or irreversible injury.

##### DANGER

Refers to a hazard that could directly cause death, serious or irreversible injury.

#### Structure of the Warning: All Warnings are Structured as Follows

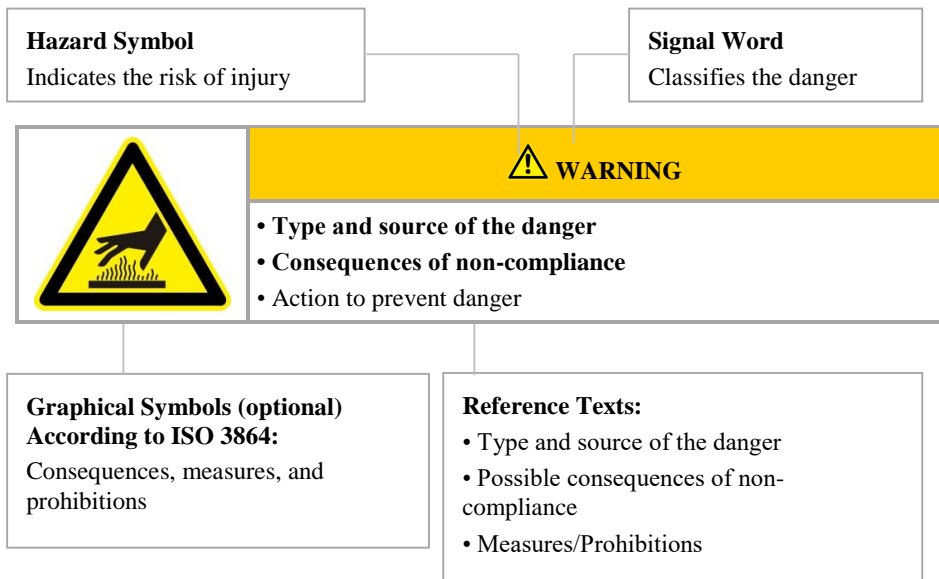

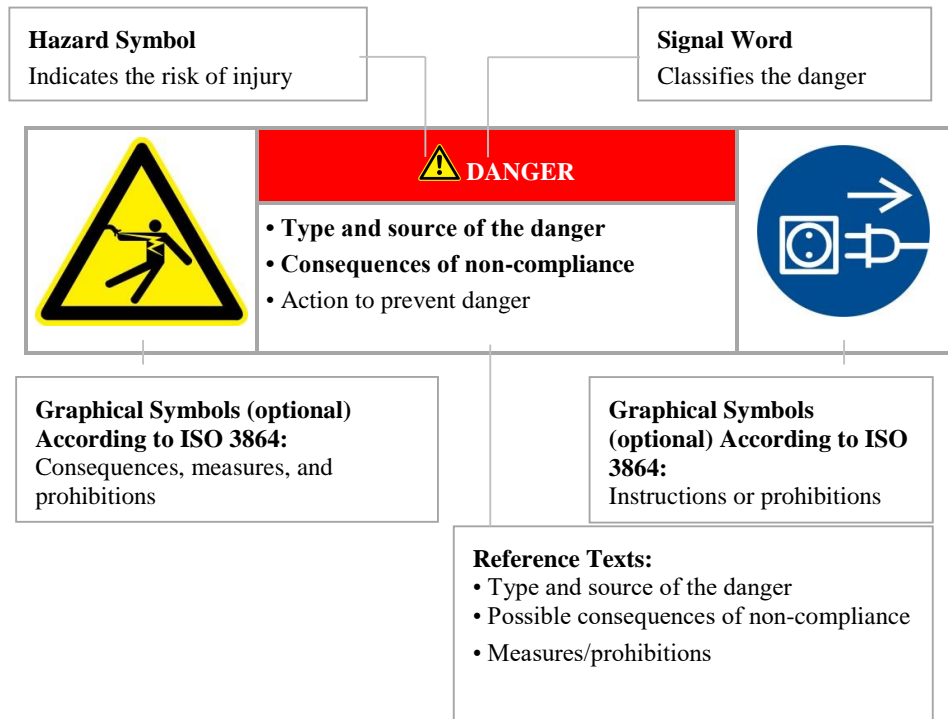

or





**Information Symbols in the Instructions:**

- 

**Note**  
Below this symbol you will find instructions and particularly useful information.
- 

**Rule - Rule Sign**  
This symbol draws attention to important rules that must be observed. Rule signs protect people against injury and show what is to be done in certain situations.
- 

**Rule – Important Information for Operators**  
This symbol draws the operator's attention to important information and operating instructions that must be observed.
- 

**Rule – Important Information for Maintenance Personnel**  
This symbol draws the maintenance personnel's attention to important operating and maintenance instructions (service) that must be observed.
- 

**Rule – Pull Out the Power Plug**  
This symbol tells the operator to pull out the power plug.



**Rule – Lift only with Several People**

This symbol draws the personnel's attention to the fact that this device may only be lifted and moved to its final destination by several people.



**Warning – Hot Surface, Do Not Touch**

This symbol warns the operator that the surface is hot and should not be touched.



**Warning – Danger of Electric Shock**

This symbol warns the operator that there is a risk of an electric shock if the following warnings are not heeded.



**Warning – Danger if Heavy Loads are Lifted**

This symbol warns the operator of the potential dangers of lifting heavy loads. Ignoring this can lead to injury.



**Warning – Fire Danger**

This symbol warns operators of the danger of fire if the following information is not followed.



**Prohibited – Important Information for Operators**

This symbol warns the operator that water or cleaning products must NOT be poured over the objects. A high-pressure cleaning device must also not be used.

**Warning Signs on the Furnace:**



**Warning – Hot Surface, Danger of Burning – Do Not Touch**



You may not always realize that surfaces, such as furnace components, furnace walls, doors and materials, and even liquids are hot. Do not touch the surface.



**Warning – Danger of Electric Shock!**

Warning, dangerous electric voltage



|   |   |   |
|---|---|---|
|    |  <b>DANGER</b> |  |
| <ul style="list-style-type: none"> <li>• <b>Danger from electrocution</b></li> <li>• <b>If there is no earth connection, or the earth connection is poorly connected, the result may be a deadly electrical shock.</b></li> <li>• Do not insert any metallic objects such as thermocouples, sensors or tools into the furnace chamber without having previously ensured that the plant has been correctly earthed. Entrust the job of making a earth connection between the object and the furnace housing to a qualified electrical technician. Any objects inserted into the furnace must be inserted only through those openings intended for this purpose.</li> </ul> |   |   |

### 3.2 Defined Application



The Nabertherm furnace was designed and built in conformance with a careful selection of the applicable harmonized standards and other technical specifications. Hence, it corresponds to the state of the art and assures the greatest degree of safety.

Furnaces in the **Top** and **HO** series are electrically heated furnaces for firing ceramics, glass fusing, glass and porcelain painting. Furnaces in the **F** series are for glass fusing, glass and porcelain painting.

**Improper furnace operation:**

- Any other use, such as processing of products other than those for which the furnace was intended as well as handling hazardous materials or materials dangerous to health is deemed IMPROPER and such uses must be approved in writing by Nabertherm.
- **This furnace is NOT used by certain persons (including children) with restricted physical, sensorial or mental capabilities or who have insufficient experience and/or insufficient knowledge, unless they are supervised by a person who is responsible for their safety or are instructed in how to use the furnace. Children should be supervised to make sure that they do not play with the furnace.**
- The furnace must **not** be used for heating food.
- The set-up instructions and safety regulations must be followed, otherwise the furnace will be considered improperly used, effectively cancelling any claims against Nabertherm GmbH. The EC Declaration of Conformity will cease to be valid if any modifications are made to the machine without our approval.
- The set-up instructions and safety regulations must be followed, otherwise the furnace will be considered improperly used, effectively cancelling any claims against Nabertherm GmbH.
- Operation with power sources, products, operating equipment, auxiliary materials, solvents, etc., which are listed as hazardous or which may in any way harm the health of the personnel operating the furnace is prohibited.

### The operator is liable for any resulting damages.

- The furnace may only be operated in the manner described in these operating instructions, i.e., the operating instructions must be completely read and understood.
- Under certain circumstances gases or materials may be released from the materials in the furnaces that settle on the insulation or the heating elements and destroy them. **If applicable, read the labels and instructions on the packaging of materials that you use.**
- The set-up instructions and safety regulations must be followed, otherwise the furnace will be considered improperly used, effectively cancelling any claims against Nabertherm GmbH.
- Opening the furnace while it is still hot, over 200 °C (392 °F), can lead to increased wear of the following components: insulation, door seal, heating elements and furnace housing. No liability shall be accepted for any damage to the goods or the furnace resulting from non-compliance with this warning.



This furnace was designed for **private and commercial** use. The furnace is **NOT** to be used for heating food, animals, wood, grains, etc.

The furnace must **NOT** be used to heat the workplace.

Do **NOT** use the furnace to melt ice or for similar purposes.

Do **NOT** use the furnace as a clothes dryer.



#### Note

See safety instructions in the individual sections.



#### Note

The furnace must not be operated with explosive gases or mixtures or with explosive gases or mixtures that form during the process.

This furnace has **no** safety technology for processes in which combustible mixtures can form, such as debinding.

If the furnace is to be used for such processes, the concentration of organic gases must never exceed 3 % of the lower explosive limit (LEL) in the furnace. This requirement not only applies to normal operation, but also especially to exceptions, such as process malfunctions (e.g. due to the breakdown of a unit, etc.). Ensure adequate extraction and ventilation of the furnace.

Nabertherm offers a wide range of furnaces that were especially developed for processes with flammable gases.



#### Note

**This product does not comply with the ATEX Directive and may not be used in ignitable atmospheres. The system must not be operated with explosive gases or mixtures and it must be ensured that explosive gases or mixtures do not form during the process.**

## 3.3 Requirements for the Furnace Operator



The set-up instructions and safety regulations must be followed, otherwise the furnace will be deemed to have been used improperly, effectively cancelling any claims against Nabertherm GmbH.

This level of safety can be achieved only if all the necessary measures have been taken. It depends on the furnace operator's diligence in planning these measures and controlling how they are carried out.

#### The operator must ensure that

- **This furnace is NOT used by certain persons (including children) with restricted physical, sensorial or mental capabilities or who have insufficient experience and/or insufficient knowledge, unless they are supervised by a person who is responsible for their safety or are instructed in how to use the furnace. Children should be supervised to make sure that they do not play with the furnace.**
- When ceramics, clay, or glaze are fired, they can emit gases and vapors that are harmful to your health. It is therefore necessary to make sure that the "exhaust gases" emitted from the exhaust air opening are directed outdoors in a suitable manner (ventilate the working area). If adequate ventilation cannot be ensured at the working area, the "exhaust gases" must be removed via a pipe (see "venting exhaust fumes").
- Before placing materials in the furnace, check whether they could harm or destroy the insulation or the heating elements. Materials that could damage the insulation include: alkalis, alkaline earths, metal vapors, metal oxides, chlorine compounds, phosphorous compounds, and halogens. **If applicable, read the labels and instructions on the packaging of materials that you use.**
- The furnace is operated only in a perfect operating condition and, in particular, that the functions of the safety components are checked regularly.
- Necessary personal protective equipment is available. Example: protective gloves, suitable apron, etc.
- This instruction manual is to be kept beside the furnace. These instructions must be available at all times for anyone working with or on the furnace;
- All the safety and operating instruction signs on the furnace can be read properly. Damaged or unreadable signs must be replaced immediately,
- Personnel are informed regularly about all issues involving occupational safety and environmental protection and are familiar with all the operating instructions, especially those involving safety,
- If the furnace is used commercially:  
Observe the safety regulations applicable in your country. In Germany, the furnace must be checked by a qualified electrician at defined intervals in accordance with a regulation issued by the employers' accident insurance fund.



#### Note

In Germany, the general accident protection guidelines must be observed. The accident prevention regulations applicable in the country where the furnace is installed must be observed.

### 3.4 Protective Clothing



Wear heat-resistant gloves to protect your hands.

### 3.5 Basic Measures During Normal Operation



#### Risks during normal operation

Before switching the furnace on, check and ensure that only authorized persons are in the working area of the furnace and that no one can be injured as a result of operating the furnace.

Each time, before starting production check and ensure that all the safety equipment functions as intended (for example, that the contact safety switch switches the heating off when the lid is opened).

Before starting production each time, check the furnace for obvious damage and ensure that it is operated only in a perfect condition. Report any defects to Nabertherm Service immediately.

Before starting production each time, remove all materials and objects that are not needed for production from the working area.

**At least once every day (see also Servicing and Maintenance) check the following:**

- Check the furnace for obvious external damage (visual check), for example insulation, heating elements, power cable, exhaust gas system, if applicable.
- Check that all safety equipment is functioning (for example, that the contact safety switch switches the heating off when the door is opened).

### 3.6 Basic Measures in Case of Emergency

#### 3.6.1 What to Do in an Emergency



#### Note

**The power plug is to be pulled out to stop the furnace in case of an emergency.** Therefore, the power plug must be accessible at all times when the furnace is operating so that it can be pulled out quickly in case of an emergency.

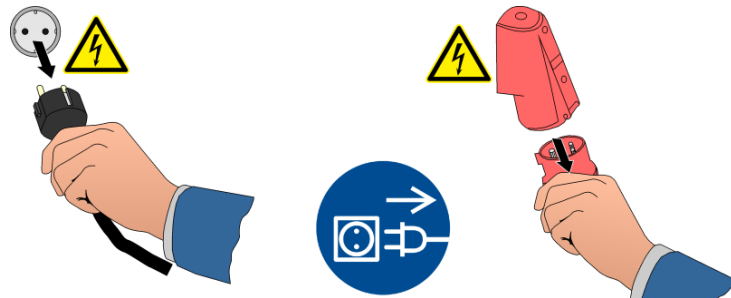

Fig. 6: Pull the power plug (similar to picture)





#### Risks during Normal Operation!

Switch the furnace off immediately in case of unexpected occurrences in the furnace (e.g. a lot of smoke or unusual smells). Wait until the furnace has cooled naturally to room temperature.

**In case of fire, keep lid closed.**  
**Immediately remove the power plug.**  
 Keep doors and windows closed. This prevents smoke spreading.  
 Immediately notify the fire service, regardless of the extent of the fire.  
 When you phone the fire service, remain calm and speak clearly.



|   |   |  |
|---|---|--|
|  <b>DANGER</b> |   |  |
|               | <ul style="list-style-type: none"> <li>• <b>Danger of electric shock.</b></li> <li>• <b>Risk of fatal injury.</b></li> <li>• Work on electrical equipment may be carried out only by qualified electricians or by trained personnel authorized by Nabertherm.</li> <li>• Before starting work, pull out the power plug</li> </ul> |  |

### 3.7 Basic Measures for Servicing and Maintenance



Maintenance work must be performed by authorized persons, following the maintenance instructions and the accident prevention regulations. We recommend that the maintenance and repair work be carried out by the service team of Nabertherm GmbH. Non-compliance may cause injuries, death, or considerable damage to property.

Switch the furnace off at the power supply **and pull out the plug.**

The furnace must be completely empty.

When cleaning furnaces, control cabinets, or electrical equipment housings, never spray them with water.

When maintenance or repair work has been completed, before recommencing production ensure the following:

- Check that loosened screw connections/tensioning straps have been re-tightened,
- Reinstall protective equipment, screens, and filters (if applicable),
- Remove all material, tools, and other equipment used for the maintenance or repair work from the working area of the furnace,
- Power cables may be replaced only with similar, approved cables.

### 3.8 General Risks with the Furnace



- Bypass connection/exhaust air pipe/lid/handle all become hot when the furnace is operating.
- **Danger of burning.**
- Do NOT touch the bypass connection/exhaust air pipe/lid/handle when the furnace is operating.

- Do not insert objects into the openings in the furnace housing, the exhaust air holes or the cooling slits of the switchgear or the furnace.
- **Danger of electric shock.**
- Do NOT insert any objects.

- **Danger of electric shock**
- **Risk of fatal injury**
- The furnace must NOT become wet during operation or maintenance

- **Danger of explosion from materials in the furnace**
- **Risk of fatal injury**
- Do NOT insert explosive substances into the furnace when it has reached its operating temperature.
- NO explosive dusts or solvent-air mixtures inside the furnace.
- Do NOT operate the furnace in areas where there is a risk of explosion.
- NO explosive dusts or solvent-air mixtures in the surrounding area.

- **Fire hazard if an extension cable is used**
  - **Risk of fatal injury**
- With 230 V furnace models make sure that:
- The distance between the circuit breaker and the power socket that the furnace is connected to is as short as possible.
  - NO power board or extension cable is used between the power socket and the furnace.



#### Risks during normal operation

Do not place objects on top of the furnace. There is a risk of fire or explosion.

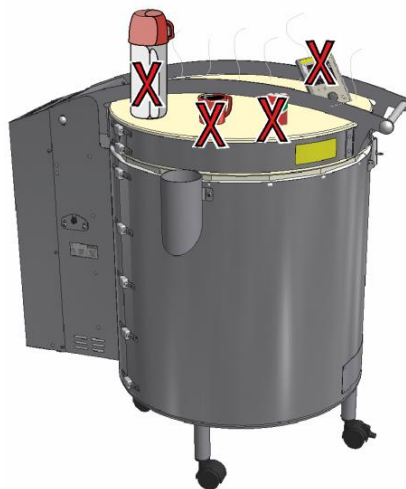

## 4 Transportation, Installation and Initial Start-Up

### 4.1 Delivery

#### Check that everything is complete

Compare the delivered items with the delivery note and the purchase order documents. **Immediately** notify the carrier and Nabertherm GmbH of any missing or damaged parts, as complaints at a later date cannot be acknowledged.

#### Danger of injury

When the furnace is being lifted, parts of the furnace or the furnace itself could topple over, slip, or fall. Before the furnace is lifted, make sure no one is in the working area. Appropriate protective gloves must be worn.

#### Safety Instructions

- Industrial trucks (e.g.: crane/pallet truck) must be operated only by authorized personnel. The operator bears sole responsibility for safe operation and the load.
- Use only lifting equipment with sufficient load-bearing capacity.
- When the furnace is being lifted, make sure that the ends of the forks or the load do not catch on neighboring goods. Use a crane to move tall parts, such as control cabinets.
- Lifting gear must be attached only to positions that have been designated for this purpose.
- Attachments, piping, or cable conduits must never be used to affix lifting gear.
- Attach transportation equipment only to positions intended for this purpose.



#### Note

Wear protective gloves when installing the furnace.



#### Risks during normal operation

Suspended loads are dangerous. Working beneath a suspended load is prohibited. There is a risk of fatal injury.



#### Note

Safety and accident prevention guidelines applicable for forklift trucks must be followed.

#### Transportation with a Pallet Truck

Observe the maximum permitted capacity of the pallet truck.

1. Our furnaces are delivered ex works on wooden frames to facilitate unloading. Transport the furnace in its original packaging and with suitable equipment to prevent any damage. Remove the packaging only when the furnace is in its final location. When transporting the furnace, make sure it is secured against sliding, toppling over, and damage. The furnace should be transported and installed by at least two persons. **Do not store the furnace in damp rooms or outdoors.**
2. Push the pallet truck underneath the transportation frame. Make sure that the pallet truck is **completely** beneath the frame. Pay attention to neighboring goods.



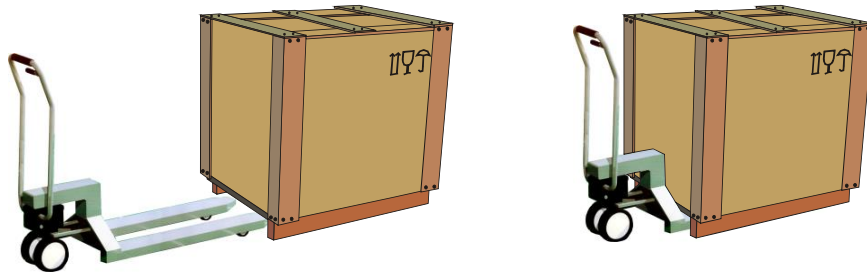

Fig. 7: Pallet truck is pushed **completely** beneath the transportation frame

3. Lift the furnace carefully and pay attention to its center of gravity. When the furnace is being lifted, make sure that the ends of the forks or the load do not catch on neighboring goods.
4. Make sure that the furnace is balanced safely; if not, attach securing equipment. Push the furnace carefully, slowly and with the pallet truck at its lowest position. Do not transport the furnace on inclines.
5. Carefully lower the furnace at its final position. Pay attention to neighboring goods. Try not to set it down too abruptly.

|  |   |  |
|--|---|--|
|  | <p><b>! CAUTION</b></p> <ul style="list-style-type: none"> <li>• <b>Device may slip or topple over.</b></li> <li>• <b>Damage to the device.</b></li> <li>• Risk of injury from lifting heavy loads.</li> <li>• Transport device only in original packaging.</li> <li>• Several people must carry the device.</li> </ul> |  |
|--|---|--|

## 4.2 Unpacking



### Note

The furnace packaging prevents damage during transportation. Make sure that you remove all packaging material (also inside the Furnace Chamber). Keep the packaging and transportation securing equipment in case it is needed for future transportation or storage.

At least two people are needed to carry/transport the furnace, more for larger furnaces.



Wear protective gloves

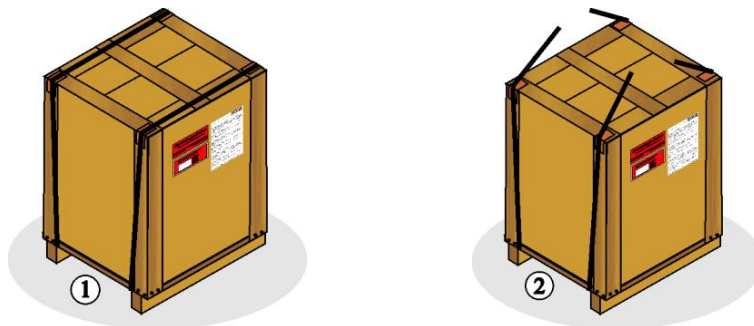



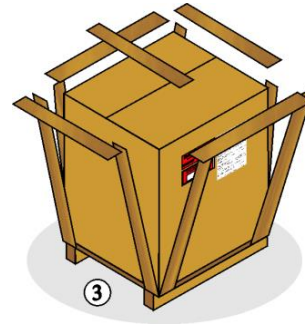
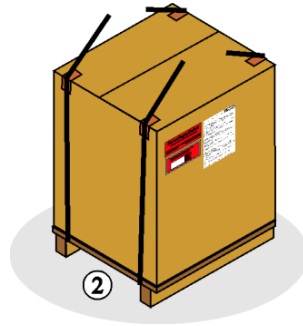

1. Check the transportation packaging for any signs of damage.
2. Remove straps from the transportation packaging.
3. Loosen the screws and remove the wooden frame from the cardboard box (if applicable)

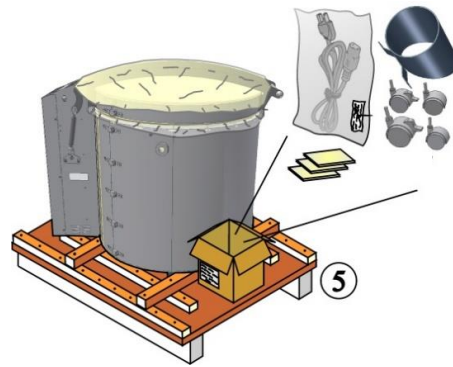
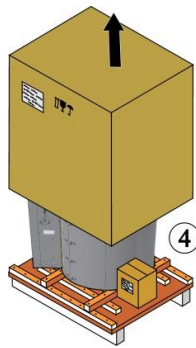

4. Carefully lift the cardboard box and remove it from the pallet. Compare the delivered items with the delivery note and the order documents, see "Delivery".
5. The pallet contains a packaging unit for accessories (Example: power cable, bypass connection, ceramic shelves, castors and tools to assemble the castors and the bypass connection).

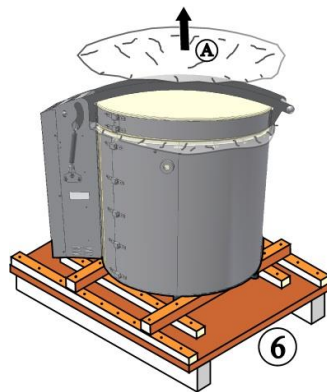

6. Remove the top protective film (A) from the furnace.
7. To carry the furnace, place your hands beneath the furnace on the side (near the feet) and make sure that you have a good grip. **Wear protective gloves when installing the furnace.** Keeping your back straight, lift the furnace from the pallet and

carefully lower it at the point where it is to be installed. The furnace should be transported by at least 2 people.

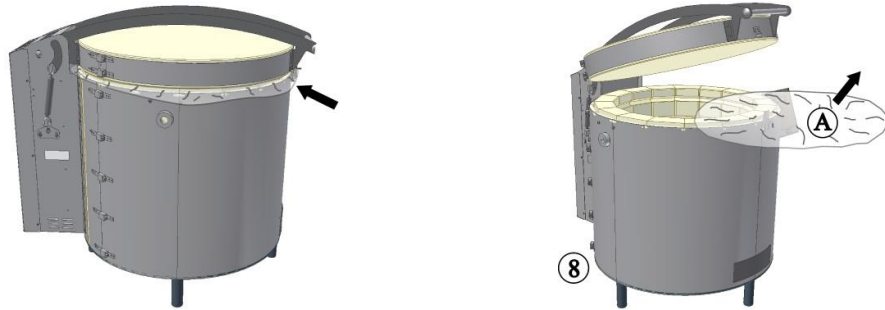

8. Remove the protective film that protects the insulation between the furnace and the lid. (A) Make sure that you remove all the packaging material. Keep the packaging and transportation securing material (if applicable) in case it is needed for future transportation or storage of the furnace.

|  |   |  |
|--|---|--|
|  | <p><b>⚠ CAUTION</b></p> <ul style="list-style-type: none"> <li>• <b>Device may slip or topple over.</b></li> <li>• <b>Damage to the device.</b></li> <li>• Risk of injury from lifting heavy loads.</li> <li>• Transport device only in original packaging.</li> <li>• Several people must carry the device.</li> </ul> |  |
|--|---|--|

### 4.3 Transport Securing Device/Packaging



**Note**

No special transportation securing equipment is available for this furnace

The furnace packaging prevents damage during transportation. Make sure that you remove all packaging material (also inside the Furnace Chamber). All packaging material can be recycled. The packaging was designed so that no special description is necessary.



**Safety Information**

Do not allow children to play with packaging parts. They are at risk of suffocation from folding boxes and plastic film.

### 4.4 Constructional and Connection Requirements

#### 4.4.1 Installation (Furnace Location)

When the furnace is being installed, these safety instructions must be followed:

- The furnace must be installed in a dry room as stated in the safety instructions.

- The surface (floor or bench) where the furnace is to be installed must be level to permit the furnace to stand upright. Place the furnace on a **non flammable** surface (fire safety class A DIN 4102 – Example: concrete, tiles, glass, aluminum or steel) so that any hot material falling from the furnace cannot ignite the surface.
- The load-bearing capacity of the bench (e.g. bench-top model Top 16/R) must be sufficient to take the weight of the furnace and accessories.

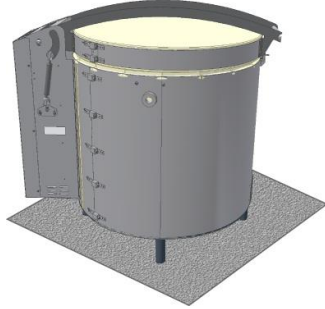

Non-flammable surface



Top 16/R Bench (accessory)

Fig. 8: Example: Non flammable surface (similar to picture)

In spite of its good insulation, the furnace radiates heat from its outer surfaces. If necessary, this heat must be dissipated (**contact a ventilation engineer if necessary**). **Flammable materials must be kept at least 0.5 m (safety distance S) away from the furnace.** In some cases, the distance must be greater because of specific local conditions. The minimum distance between the furnace and non-flammable materials may be reduced to 0.2 m at the sides. If the charge emits gases or vapors, ensure adequate ventilation at the installation site and/or a suitable exhaust air venting system. If required, the customer must provide a suitable vent for combustion exhaust gases.

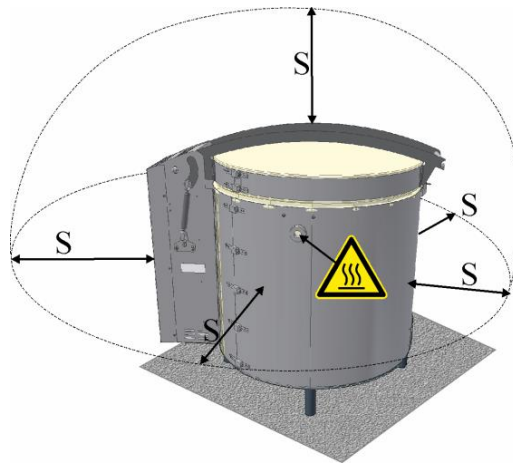





Fig. 9: Minimum safety distance to flammable materials (similar to picture)

|   |  |
|---|--|
|  |  <b>DANGER</b>   |
|   | <ul style="list-style-type: none"> <li>• Risk of fire, danger to health</li> <li>• Risk of fatal injury</li> <li>• Adequate ventilation must be ensured at the installation location to remove exhaust heat and exhaust gases</li> </ul> |



### Note

Before starting the furnace for the first time, allow it to acclimatize at its installation location for 24 hours.

|  <b>DANGER</b> |  |
|--|--|
|                 | <ul style="list-style-type: none"><li>• <b>Danger associated with the use of an automatic extinguishing system</b></li><li>• <b>Danger to life from electrocution through wetness, suffocation caused by extinguishing gas, etc.</b></li><li>• If automatic extinguishing systems are in place to fight fires and protect the building, e.g. sprinkler systems, care must be taken during their planning and installation that no additional hazards are created, for example by extinguishing a pilot light, mixing hardening oil and extinguishing water, shutdown of electrical equipment, etc.</li></ul> |

## 4.5 Assembly, Installation, and Connection

### 4.5.1 Assembling the Base Extension (Accessory)

#### Base Extension for Fusing Top Loader Model F ...

Remove the base from the packaging and compare the parts with the list below.

| No. | Quantity | Name                                      |
|-----|----------|---|
| 1   | 2        | Brace, long                               |
| 2   | 2        | Brace, short                              |
| 3   | 4        | Feet with castors, two with locking brake |
| 4   | 8        | Collar screw M8                           |
| 5   | 1        | Open-end wrench                           |

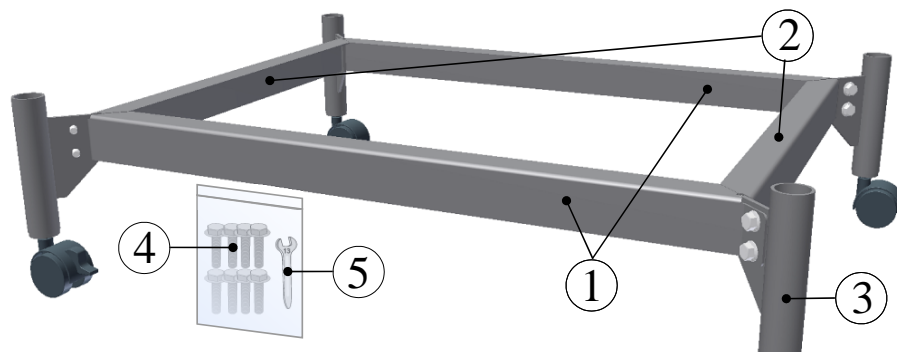

Fig. 10: Parts of the base (similar to picture)

- Assemble one foot (3) with two screws (4) (with one long (1) and one short (2) brace). Loosely tighten the screws with the supplied tool (5).
- Assemble the other feet and braces. When all the feet and braces are assembled, tighten the screws.

- Screw the castors that you removed on to the bottom of the feet (see “Assembling the Castors”).
- Carefully place the furnace on to the frame. Wear protective gloves and lift the furnace only by the base. At least two people are needed to lift the furnace, more for heavier furnaces.

### Base Extension Top Loader Model Top ...

Remove the base from the packaging and compare the parts with the list below.

| No. | Quantity | Name                         |
|-----|----------|------------------------------|
| 3   | 2        | Base extension Top 45/Top 60 |

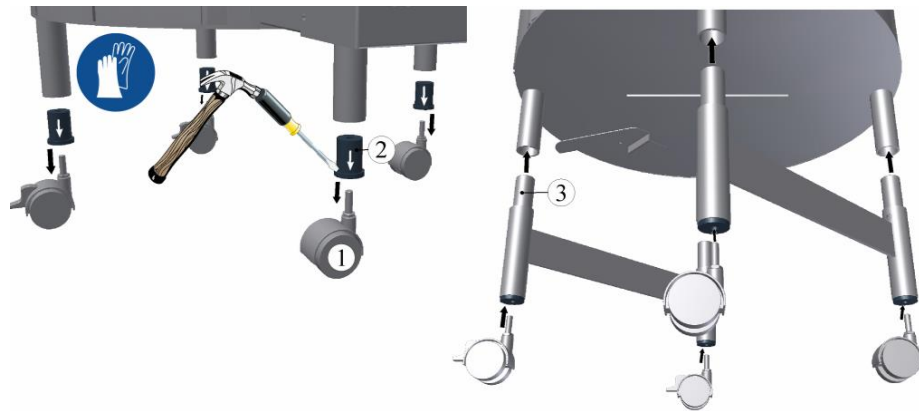

Fig. 11: Assembling the base extension (similar to picture)

- To remove the castors (1) pull them firmly downwards.
- Carefully loosen the sleeves (2) (on the furnace feet) with a wide screwdriver and hammer for example.
- Insert the two base extensions (3) on to the furnace feet. Make sure that the base extension sits firmly.
- Screw the castors that you removed on to the bottom of the feet (see “Assembling the Castors”).

## 4.5.2 Assembling the Castors

If required, the castors that are delivered can be attached to the furnace feet. We recommend that the castors with the locking brake are attached to the front of the furnace. The number of castors depends on the number of feet and varies depending on the furnace model. Furnace model Top 16/R (bench-top model) is delivered without castors. **Wear protective gloves when assembling the castors or when lifting the furnace.** Only lift the furnace from the base. **The furnace must NOT be placed on its side, as this will damage the insulation and heating elements and thus destroy the furnace.** Nabertherm accepts no liability for damage resulting from assembly of the castors.

- If required, the supplied castors can be inserted under the feet of the furnace.

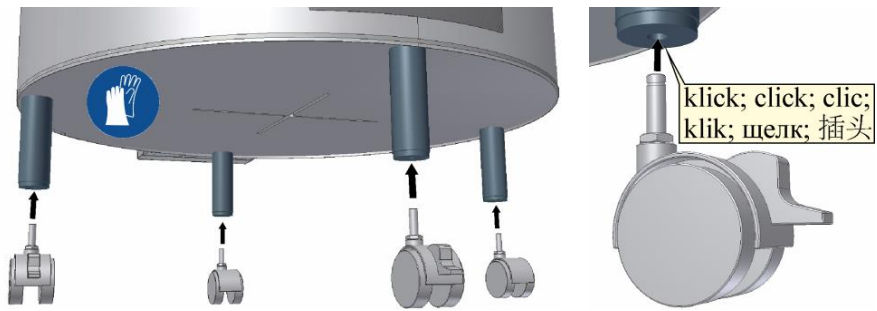

Fig. 12: Assembling the castors (similar to picture)

**Assembly recommendation**

Compliance with our recommendations does not release users of our products from their personal responsibility in relation to local situations and conditions. However, several general recommendations should be considered:

- In the case of furnaces up to 60 kg we recommend that you tip the furnace carefully on its feet. Grip below the furnace (1) and carefully tip it to the side. Assemble the first castor and then carefully release your grip on the furnace. Repeat this process for all the castors. We recommend that a second person prevents the furnace from tipping too much, falling over or rolling away.(3)/(4).

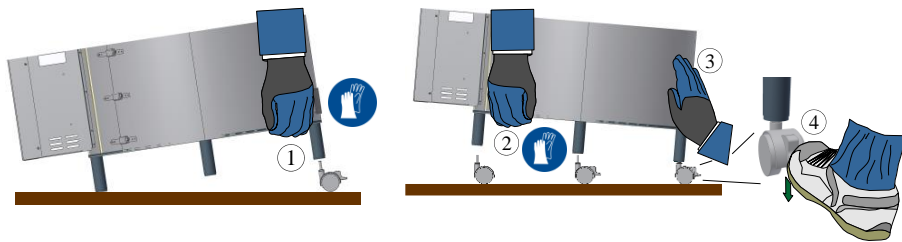
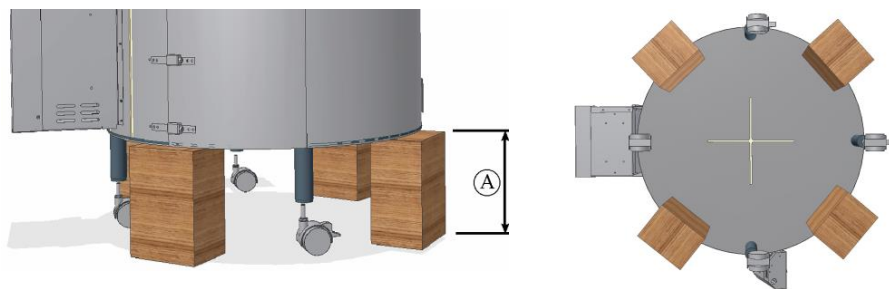

Fig. 13: Example: Assembling castors on furnaces up to 60 kg (similar to picture)

- Do NOT tip furnaces above 60 kg on their feet. There is a risk of the feet “breaking off” if you tip the furnace. To insert the castors, we recommend that you sit the furnace on four suitable wooden blocks. These blocks should be at least 20 cm high so that the castors can be screwed beneath the feet. At least two people are needed to lift the furnace, more for heavier furnaces.



A = min. 20 cm

Furnace base from below

Fig. 14: Example: Assembling castors on furnaces over 60 kg (similar to picture)

- When the furnace is in position, lock the brakes on the castors.

When the bypass connection has been attached to and aligned on the furnace, you can then assemble an exhaust gas system if this is required. See "Exhaust Gas System" for more information about exhaust gas.

### 4.5.3 Assembling the Controller (Depending on the Model)

Attach the supplied controller with holder (model-related) to the furnace.

At the controller position there are screws to attach the holder; these must be unscrewed beforehand.

Place the controller holder (2) with the screws loosened on to the correct position on the furnace and fasten it with suitable tools (3).

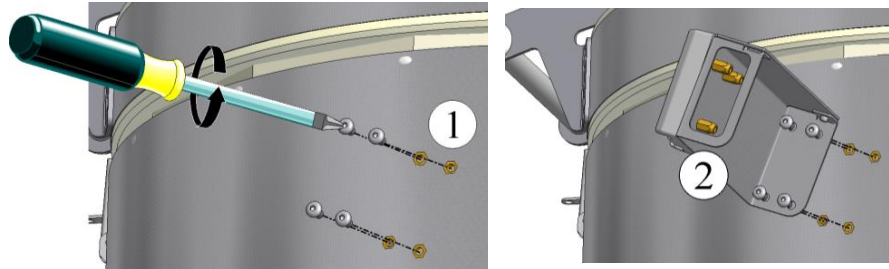

Fig. 15: Install the holder on the furnace housing (similar to picture)

Tighten the screws (3) of the holder and check that it sits properly (4).

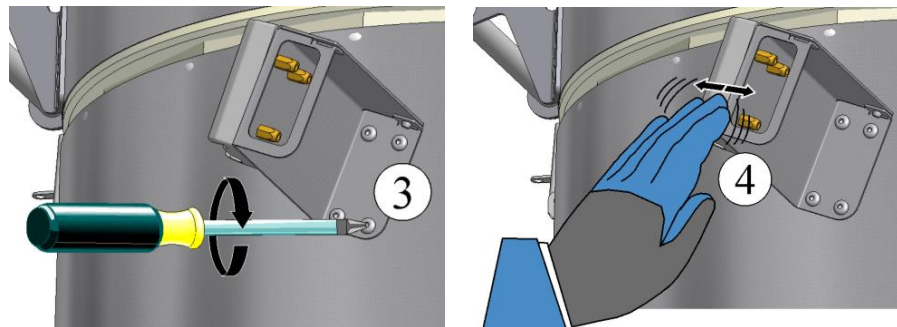

Fig. 16: Tighten the screws on the holder (similar to picture)

Place the controller in the holder on the furnace.



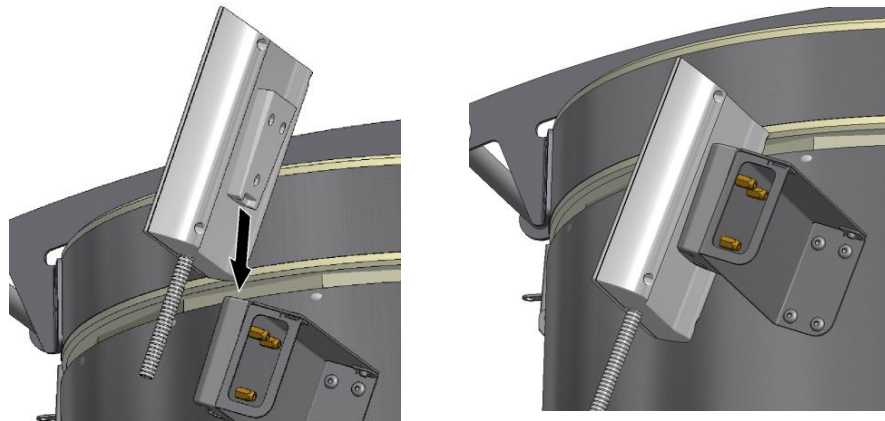

Fig. 17: Place the controller in the holder (similar to picture)

#### 4.5.4 Place the Controller in the Holder on the Furnace (model-related)

Make sure that the controller is placed correctly in the holder. If this is ignored, the controller may be damaged or destroyed. Nabertherm accepts no liability if the controller is not handled properly.



Fig. 18: Place the controller in the holder on the furnace (similar to the picture)

The controller can simply be removed from the holder for especially ergonomic handling and more comfortable operation.

#### 4.5.5 Assembling the Bypass Connection

The bypass connection that is part of the delivery is fixed to the side of the furnace. Furnaces in the top loader F series... have no bypass connection. Furnace model Top 16/R is delivered without a bypass connection. This model is ventilated via a hole in the middle of the lid.

At the position where the bypass connection is fixed are two screws (1) to assemble it; these must be removed beforehand.

Place the bypass connection (2) with the screws on to the correct position on the side of the furnace and fix it with suitable tools.



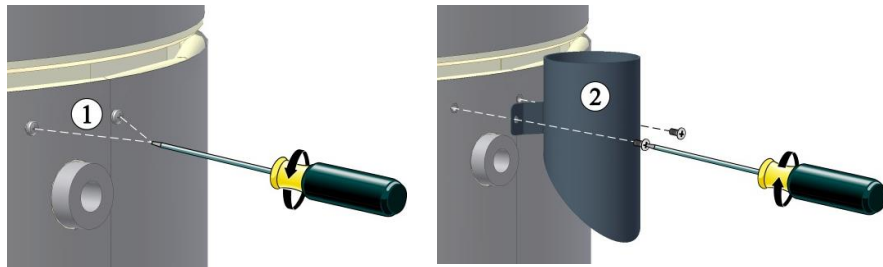
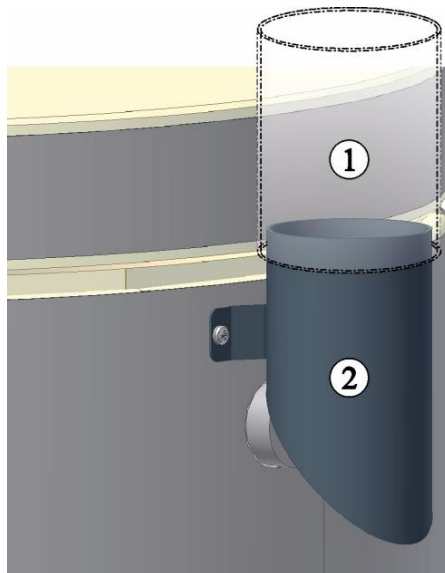

Fig. 19: Assembling the bypass connection (similar to picture)

When the bypass connection has been attached to and aligned on the furnace, you can then assemble an exhaust gas system if this is required. See "Exhaust Gas System" for more information about exhaust gas.



- 1 Assembling the exhaust air piping: If required, see "Exhaust Gas System"
- 2 Bypass connection

Fig. 20: Assembling the exhaust gas piping on the bypass connection (similar to picture)

#### 4.5.6 Venting Exhaust Fumes

When ceramics are fired, depending on the quality of the clay and/or glaze, they can emit gases and vapors that are harmful to your health. It is therefore necessary to make sure that the "exhaust gases" emitted from the exhaust air opening are directed outdoors in a suitable manner (ventilate the working area). If adequate ventilation cannot be ensured at the working area, the "exhaust gases" must be removed via a pipe. We recommend that you connect a pipe to the furnace to remove the exhaust gases.

A suitable metal exhaust gas pipe with NW80 can be used to vent the gases. Use only metal pipes (example: stainless steel). The pipe must be attached facing upwards and be fixed to the wall or ceiling. Adequate room ventilation is needed to achieve the bypass effect. Vapors may not be extracted through a fan.

Assume a maximum exhaust gas temperature of approx. 200 °C (392 °F) for the piping system. There is a risk of burning at the bypass connection and the piping. Make sure that the wall duct is made from (A) heatproof material.

If the furnace is installed in a "passive house" it must be ensured that the room has an adequate fresh air supply. Because of potential aggressive vapors, we do not recommend that it is connected to the house ventilation system. We recommend a separate furnace room that can be ventilated adequately.

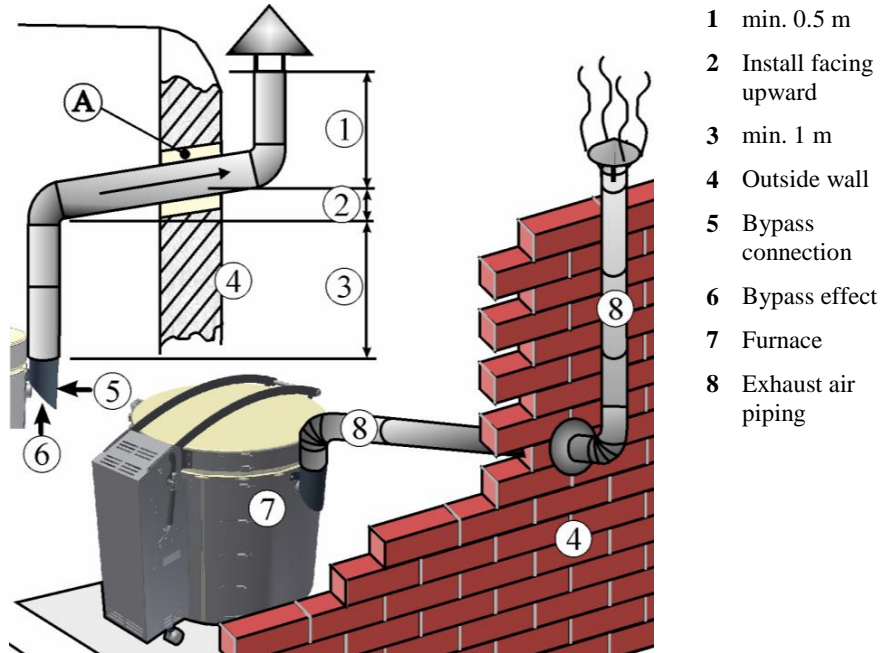

Fig. 21: Example: Assembling exhaust air piping (similar to picture)

**Note**

Roof work and/or masonry by the customer is required for the exhaust gas extraction. The size and design of the exhaust gas system must be defined by a ventilation engineer. The accident prevention regulations applicable in the country where the furnace is installed must be observed.

**Volumetric Flow Quantities and Temperature Behavior**

Use the exhaust air volumetric flow rates in the table below to calculate the exhaust air piping via the bypass connector. If the exhaust air piping is designed continuously rising with DN 80 according to our recommendations, it can be assumed that this value will be achieved if this volume of air can also be fed to the room from outdoors (ventilation opening with a minimum cross section of 50 cm<sup>2</sup>).

In the case of furnaces with an exhaust air flap and also the fresh air fan option the volumetric flow rate is much higher and can be extracted from the room only in combination with an exhaust air hood (flue).

| Furnace model                        | Maximum temperature inside the furnace in °C | ① Flow rate of cooling fan <sup>1</sup> m <sup>3</sup> /h | ② Flow rate of exhaust air flap <sup>1</sup> m <sup>3</sup> /h | ③ Flow rate of bypass connector <sup>1</sup> m <sup>3</sup> /h | ④ Flow rate of exhaust air hood <sup>1</sup> m <sup>3</sup> /h |
|--------------------------------------|--|---|--|--|--|
| N 40 E(LE) –<br>N 280 E              | 1300 (1200)                                  | -   | -  | approx. 25   | -  |
| N 100(H)(14)(G) –<br>N 300(H)(14)(G) | 1300 (1340)<br>(1400) (900)                  | max. 600  | approx. 40   | -  | approx. 260  |

| Furnace model                                      | Maximum temperature inside the furnace in °C   | ① Flow rate of cooling fan <sup>1</sup> m <sup>3</sup> /h | ② Flow rate of exhaust air flap <sup>1</sup> m <sup>3</sup> /h | ③ Flow rate of bypass connector <sup>1</sup> m <sup>3</sup> /h | ④ Flow rate of exhaust air hood <sup>1</sup> m <sup>3</sup> /h |
|--|--|---|--|--|--|
| N 440(H)(14)(G) – N 500 E                          | 1300 (1340) (1400) (900)   | max. 600  | approx. 40   | -  | approx. 260  |
| N 660(H)(14)(G) – N 1000(H)(14)(G)                 | 1300 (1340) (1400) (900)   | max. 600  | approx. 40   | -  | approx. 400  |
| Top 16 – Top 220                                   | 1320   | -   | -  | approx. 25   | -  |
| LH 15/12 - LF 120/14                               | 1200/1300/1400   | max. 600  | approx. 90   | approx. 25 <sup>2</sup>  | approx. 400  |
| LH 216/12 – LH 216/14                              | 1200/1300/1400   | max. 600  | approx. 90   | approx. 25 <sup>2</sup>  | approx. 400  |
| ①a   | 1x cooling fan D05 ambient air (~ 25 °C)   |   |  |  |  |
| ②a   | Additional air drawn from the environment (mixing air flow) (~ 35 °C)  |   |  |  |  |
| ③a   | The exhaust air must be dissipated and the maximum temperature defined by the customer. It must be ensured that the flow of hot air emitted from the furnace is not hazardous to people, property or the building. |   |  |  |  |
| ④a   | Recommended exhaust air fan (not part of the delivery/must be provided by customer)  |   |  |  |  |
| <sup>1</sup> if present (model-related)            |  |   |  |  |  |
| <sup>2</sup> only when cooling fan is switched-off |  |   |  |  |  |

Fig. 22: Flow rates and temperature patterns

The information described above and in the table relates exclusively to extraction of the gases from the furnace. The heat occurring in case of fire may make additional room ventilation necessary, depending on the size of the room. As the heat depends to a great extent on the firing program, it is not possible to provide precise data. 1/3 of the heating power of the respective furnace can be used as a guide for dimensioning room ventilation.

**Warning:**

Active ventilation of the installation room must not cause underpressure in the room, as otherwise extraction of the exhaust air from the furnace via the bypass connector will be affected.

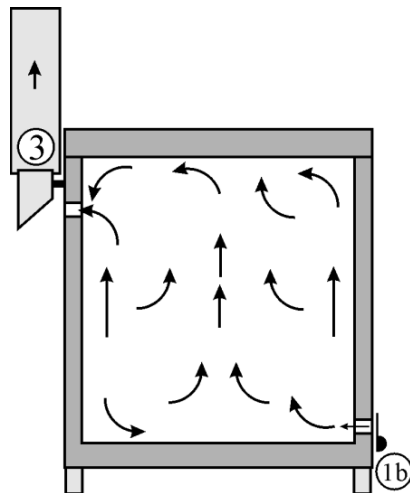

Example: Furnace with air inlet opening (1b) and bypass connection

## 4.5.7 Connecting the Furnace to the Power Supply

The customer must ensure that the surface has adequate load-bearing capacity and that the necessary energy (electricity) is provided.

- The furnace must be installed according to its intended use. The power connection must correspond to the values on the furnace's type plate.
- The power socket must be close to the furnace and be easily accessible. The safety requirements are not met if the furnace is not connected to a socket with a protective ground contact.
- With **230 V** furnace models pay attentions that:  
the distance between the circuit breaker and the power socket that the furnace is connected to is as short as possible. **NO** power board or extension cable is used between the power socket and the furnace.
- The power cable must not be damaged. Do not place any objects on the power cable. Lay the cable so that no one can stand on it or trip over it.
- Power cables may be replaced only with similar, approved cables.



### Note

Before connecting the power, make sure that the power switch is set to "Off" or "0".

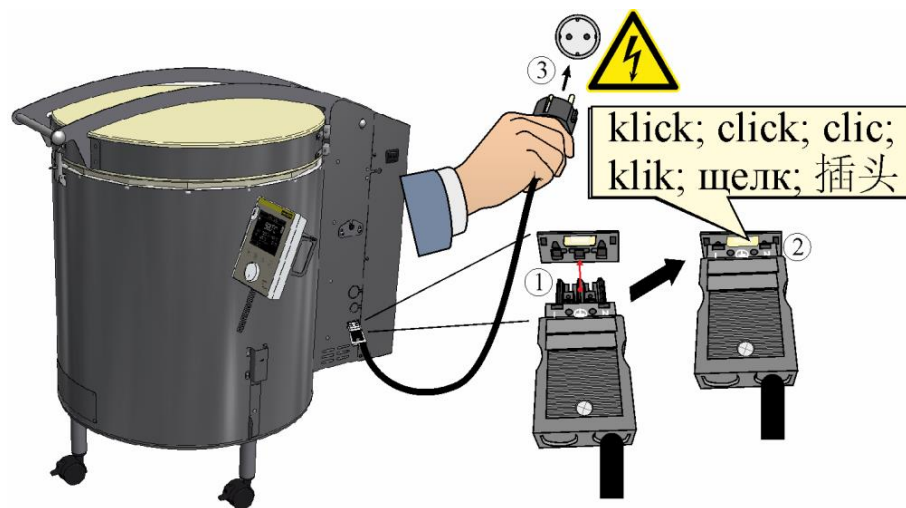

Fig. 23: Furnace up to 3600 kW (the power cable is supplied) (similar to picture)

1. Plug the supplied connection cable with snap-in coupling into the rear wall of the furnace.
2. Then connect the power cable to the power supply. Use only a grounded socket.

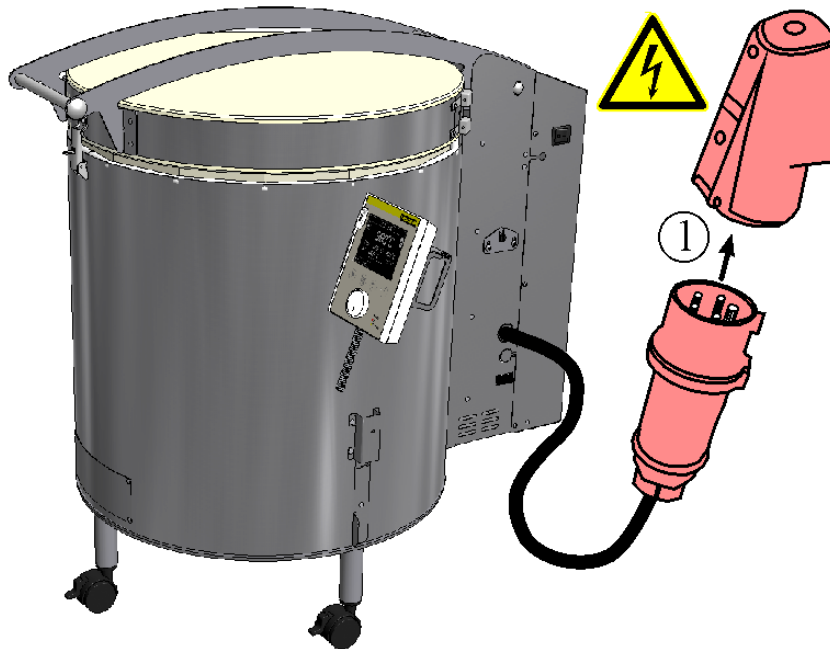



Fig. 24: Furnace from 5500 kW (CEE plug) (similar to picture)

1. Connect the power cable to the power supply. Use only a grounded socket. Grounding the furnace and the switchgear (acc. to VDE 0100, Part 410) is a requirement for the heating unit's leakage current protective circuit. Check the ground resistance (acc. to VDE 0100); see also accident prevention regulations. Electrical systems and equipment according to DGUV V3.



**Note**  
 The national regulations of the respective country of operation apply.

|   |   |   |
|---|---|---|
|  | <b>CAUTION</b>  |  |
|   | <ul style="list-style-type: none"> <li><b>Danger from incorrect voltage</b></li> <li><b>Damage to the device</b></li> <li>Check voltage before connecting and starting the furnace</li> <li>Compare the voltage with the details on the type plate</li> </ul> |   |

## 4.6 Initial Start-Up

Read the section on "Safety". When the furnace is put into operation, the following safety information must also be observed to prevent serious injury, damage to the furnace, and damage to other property.

Make sure that the instructions and information in the instruction manual and the controller instructions are observed and followed.

Before starting the furnace for the first time, make sure that all tools, foreign parts, and transportation securing equipment have been removed.

Before you switch on the furnace, make sure that you know what to do in case of faults or emergencies.

Before placing materials in the furnace, check whether they could harm or destroy the insulation or the heating elements. Materials that could damage the insulation include: alkalis, alkaline earths, metal vapors, metal oxides, chlorine compounds, phosphorous compounds, and halogens. **If applicable, read the labels and instructions on the packaging of materials that you use.**



#### Note

Before starting the furnace for the first time, allow it to acclimatize at its installation location for 24 hours.

## 4.7 Recommendations for Heating Up the Furnace for the First Time



Heat the furnace to dry out the bricks and to get a protective oxide layer on the heating elements. There may be some unpleasant odors while the furnace is heating. This is due to binder being emitted from the insulation material. It is advisable to ventilate the room in which the furnace is located well during the first heating phase.

- Half open the supply air valve (see "Operation")
- Close and lock the lid (see "Operation")
- Switch on the furnace/controller with the power switch (see "Operation")
- Heat the empty furnace, if necessary with new furnace furniture (shelves and props) to **500 °C in 6 hours**, and then heat at full power; **furnace models Top... and HO... to Tmax 1050 °C, furnace model F... to Tmax 950 °C** and keep this temperature for one hour before allowing the furnace to cool naturally. Read the controller instructions for how to enter temperatures and times.

### Insulation

The furnace insulation is made from high-grade fireproof material. Due to thermal expansion, cracks in the insulation will occur after a few heating cycles. These have no influence on the function, safety or quality of the furnace. The refractory bricks (insulation) are of a particularly high quality. Due to the manufacturing process small holes or cavities may occur. These are quite normal and underline the quality features of the bricks. These holes or cavities are not a reason for complaint.



#### Note

New furnace furniture (e.g. shelves and props) should be heated once to dry them out (as described above). When cold, heating elements are extremely brittle. Take great care when packing, emptying and cleaning the furnace.

The lid lock must be locked when during firing. To release emitted gases and vapors more quickly and to shorten the cooling phase after firing, the air inlet valve can be completely or partially opened.



**Note**

At high firing temperatures a slit may become visible along the edge of the lid. This is normal and does not compromise the furnace's function or safety.

## 5 Operation

### 5.1 Controller

B400/C440/P470



Fig. 25: Control field B400/C440/P470 (similar to picture)

| No. | Description  |
|-----|--|
| 1   | Display  |
| 2   | Control keys for "Start/Hold/Stop", "Menu" selection, "Back" function and information menu selection |
| 3   | Jog dial   |
| 4   | USB interface for a USB stick  |



**Note**

See the separate operating instructions for a description of how to enter temperatures and times and to "start" the furnace.

## 6 Operation, Display and Switch Elements (depending on design)

### 6.1 Turning on the Controller/Furnace

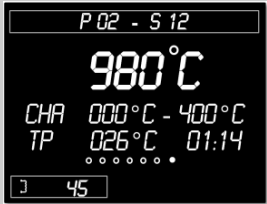
| Switching on the Controller  |   |  |
|--|---|--|
| Steps  | Display   | Comments   |
| Turn on the power switch   |  | Turn on the power switch by setting it to "I"<br>(power switch type differs depending on features/furnace model) |
| The overview screen appears.<br>After a couple of seconds, the temperature is displayed. |  | If the temperature is displayed at the controller, the controller is ready to operate.                           |

### 6.2 Turning off the Controller/Furnace

| Turn off the controller   |   |   |
|---------------------------|---|---|
| Steps                     | Display   | Comments  |
| Turn off the power switch |  | Turn off the power switch by setting it to "O"<br>(power switch type differs depending on features/furnace model) |

All the necessary settings for perfect functions have already been made at the factory.

#### 6.2.1 Handling the Controller

The controller can simply be removed from the holder for especially ergonomic handling and more comfortable operation.

After use, replace the controller in its holder.



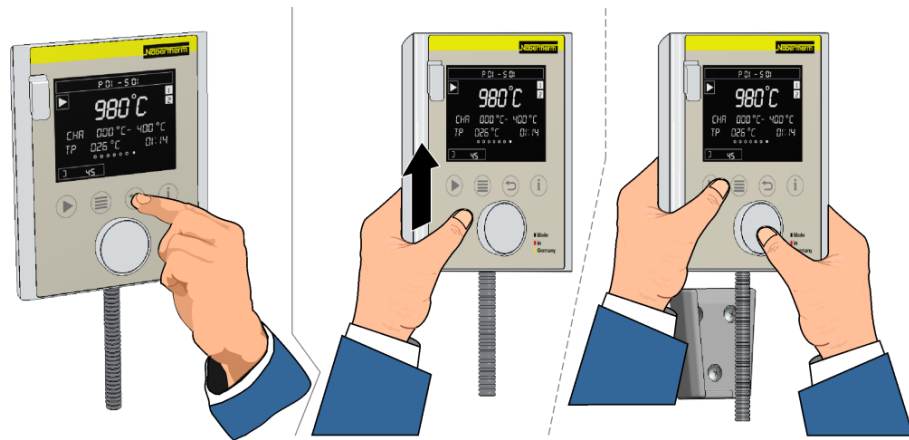

Simple operation directly on the controller

Easy and ergonomic handling by removing the controller from its holder

Fig. 26: Handling the controller (similar to picture)

Make sure that the controller is placed correctly in the holder. If this is ignored, the controller may be damaged or destroyed. Nabertherm accepts no liability if the controller is not handled properly.



Fig. 27: Place the controller in the holder on the furnace (similar to the picture)

### 6.3 Opening and Closing the Lid

#### Opening the Lid

Open the lid lock as shown in the figure below. Pull the handle lightly to open the lid slightly. It is advisable to open the lid completely to pack the furnace.

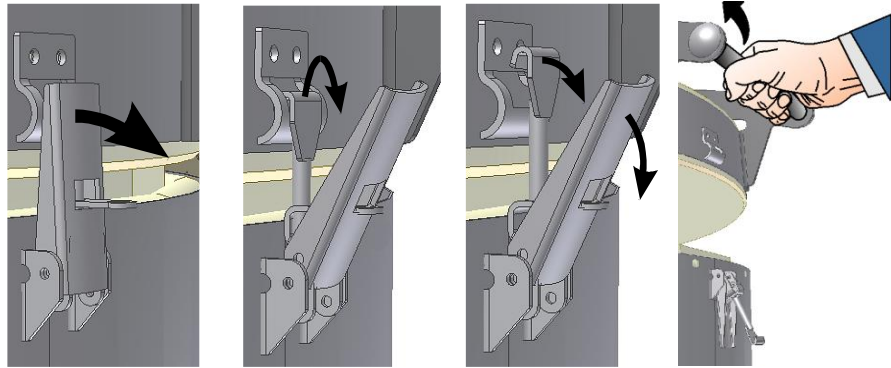

Fig. 28: Opening the lid lock (similar to picture)

### Closing the Lid

Close the lid of the furnace carefully (don't slam it shut). Close the lid lock as shown in the figure below.

When you have closed the lid, make sure that it is closed evenly all around. Check the lock/s and, if necessary, turn the snap locks to adjust them (A) so that the lock can be closed without too much effort.

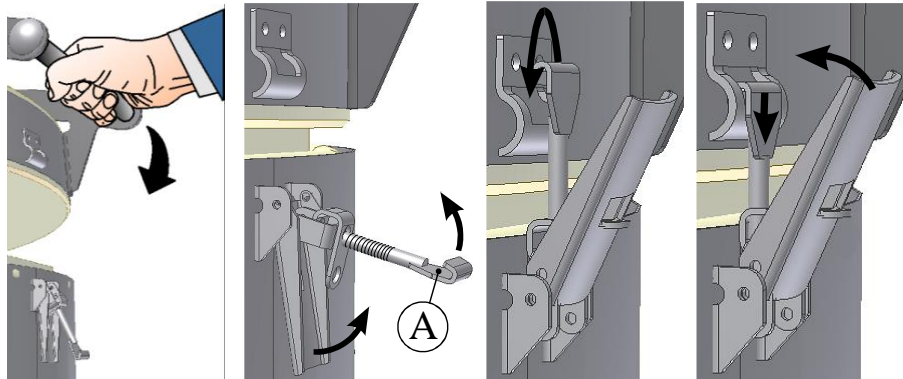
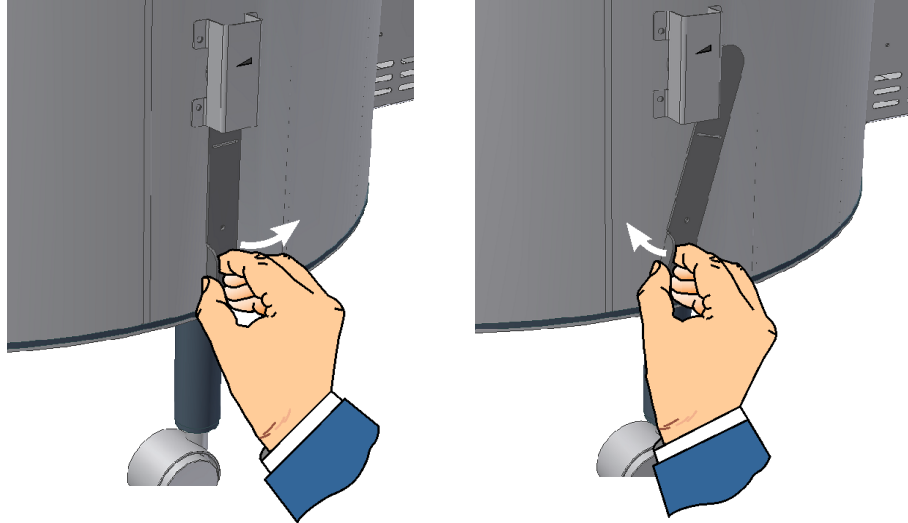

Fig. 29: Closing the lid lock (similar to picture)

## 6.4 Fresh Air Valve

The volume of air fed to the furnace can be adjusted with the fresh air valve. The fresh air valve is located on the base of the furnace. Furnaces in the fusing top loader F series have no fresh air valve.



Fresh air valve closed

Fresh air valve open

Fig. 30: Regulating the feed of fresh air on furnace model top loader Top (similar to picture)

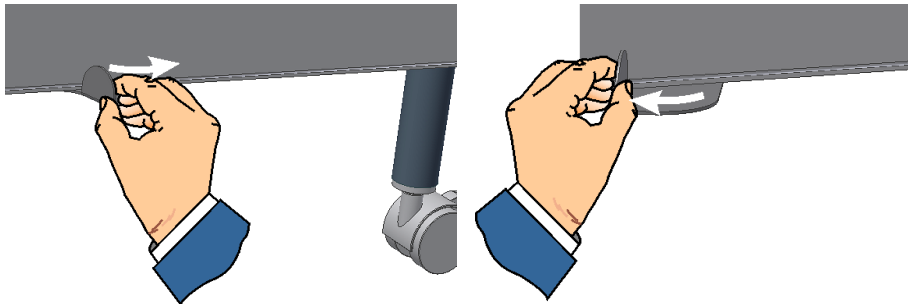

Fresh air valve closed

Fresh air valve open

Fig. 31: Regulating the feed of fresh air on furnace model top loader HO (similar to picture)

## 6.5 Loading/Charging

### Packing the Furnace

Three ceramic plates are included with the delivery (691600956) to stabilize the props and the shelves (C). We recommend that you use this three-point construction for good firing results.

### Arrangement of the Shelves and Props (Accessories)

First, place three props in a triangular design on top of the delivered ceramic plates (691600956). The ceramic plates must have been placed evenly on the floor of the furnace beforehand (A). The distance (B) between the props depends on the size of the shelves and should be as large as possible to ensure stability.

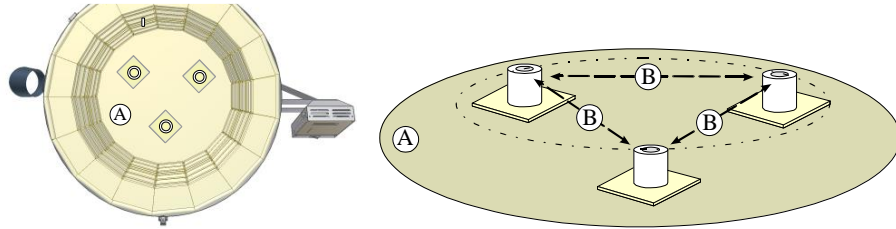

Fig. 32: Example: Even distribution of the props (accessory) (similar to picture)

Place the shelf (C) on top of the props. Now place the objects to be fired in the furnace and distribute them as evenly as possible. If a second layer is required, place props on the shelf to get the required distance between the shelves. These props should be situated exactly above each other if possible to ensure stability of the shelves.

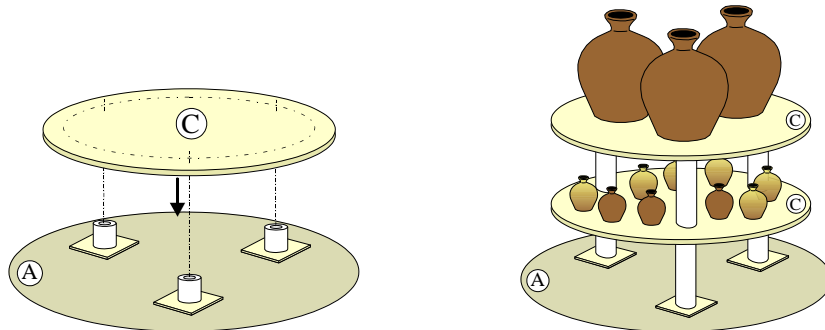

Fig. 33: Example: Several shelves (accessory) in the furnace (similar to picture)

## 6.5.1 Tips for Potters



### Note

The temperature specifications given by clay and glaze producers must be observed. They will be happy to provide you with suitable firing curves for the products.

So that your pottery, which was made with a lot of effort and love, is not destroyed, the following principles should be observed:

- Allow pottery to dry slowly – not in a heated room or in the sun.
- Dry pottery away from drafts - drafts cause uneven drying and drying cracks.
- Loosely cover outstanding parts (e.g. handles) with paper or plastic film, as they dry faster than the rest of the pot. If you don't do this, cracks may occur at the joint.
- Allow the pottery to dry for at least one week - longer in cool basements.
- Clay shrinks when it dries; in other words, the volume is reduced due to the loss of water. Objects that stick to a surface crack when they dry - therefore, always place your pottery on fresh, clean surfaces.
- Turn your pottery often as the top dries quicker than the bottom.
- Handle dry pottery carefully with both hands and don't lift it by the edges. Pottery is very fragile in this state.

### 6.5.1.1 Preset programs for ceramic applications

With Controllers B400/410, C440/450 and P470/480 the following programs are preset and can be started directly.



**Note**

In all cases, observe the information and references from the producers of raw materials that may require preset programs to be changed or adjusted. There is no guarantee that preset programs will produce optimum results. The programs set in the factory may be overwritten for personal purposes.

**Program 01**

Program name: Biscuit firing, normal ("BISCUIT NORMAL 900")

|         |        |        |         | Manual air inlet flap <sup>1</sup> | Semi-automatic air inlet flap <sup>2</sup> | Automatic air inlet flap <sup>3</sup> |
|---------|--------|--------|---------|------------------------------------|--|---------------------------------------|
| Segment | Start  | Target | Time    | Extra 1                            |  |                                       |
| 1       | 0 °C   | 600 °C | 360 min | Open manually                      | Open manually (0)                          | Opens automatically (1)               |
| 2       | 600 °C | 900 °C | 20 min  | Close manually                     | Closes automatically (1)                   | Closes automatically (0)              |
| 3       | 900 °C | 900 °C | 20 min  | -                                  | 0  | 0                                     |
| 4       | 900 °C | 0 °C   |         | -                                  | 0  | 0                                     |

**Program 02**

Program name: Biscuit firing, slow ("BISCUIT SLOW 900")

|         |        |        |         | Manual air inlet flap <sup>1</sup> | Semi-automatic air inlet flap <sup>2</sup> | Automatic air inlet flap <sup>3</sup> |
|---------|--------|--------|---------|------------------------------------|--|---------------------------------------|
| Segment | Start  | Target | Time    | Extra 1                            |  |                                       |
| 1       | 0 °C   | 600 °C | 480 min | Open manually                      | Open manually (0)                          | Opens automatically (1)               |
| 2       | 600 °C | 900 °C | 20 min  | Close manually                     | Closes automatically (1)                   | Closes automatically (0)              |
| 3       | 900 °C | 900 °C | 20 min  | -                                  | 0  | 0                                     |
| 4       | 900 °C | 0 °C   |         | -                                  | 0  | 0                                     |

**Program 03**

Program name: Glaze firing, earthenware ("GLAZE FIRING 1050")

|         |         |         |         | Manual air inlet flap <sup>1</sup> | Semi-automatic air inlet flap <sup>2</sup> | Automatic air inlet flap <sup>3</sup> |
|---------|---------|---------|---------|------------------------------------|--|---------------------------------------|
| Segment | Start   | Target  | Time    | Extra 1                            |  |                                       |
| 1       | 0 °C    | 500 °C  | 180 min | Open manually                      | Open manually (0)                          | Opens automatically (1)               |
| 2       | 500 °C  | 1050 °C | 20 min  | Close manually                     | Closes automatically (1)                   | Closes automatically (0)              |
| 3       | 1050 °C | 1050 °C | 20 min  | -                                  | 0  | 0                                     |

|         |         |        |      | Manual air inlet flap <sup>1</sup> | Semi-automatic air inlet flap <sup>2</sup> | Automatic air inlet flap <sup>3</sup> |
|---------|---------|--------|------|------------------------------------|--|---------------------------------------|
| Segment | Start   | Target | Time | Extra 1                            |  |                                       |
| 4       | 1050 °C | 0 °C   |      | -                                  | 0  | 0                                     |

#### Program 04

Program name: Glaze firing, stoneware ("GLAZE FIRING 1150")

|         |         |         |         | Manual air inlet flap <sup>1</sup> | Semi-automatic air inlet flap <sup>2</sup> | Automatic air inlet flap <sup>3</sup> |
|---------|---------|---------|---------|------------------------------------|--|---------------------------------------|
| Segment | Start   | Target  | Time    | Extra 1                            |  |                                       |
| 1       | 0 °C    | 500 °C  | 180 min | Open manually                      | Open manually (0)                          | Opens automatically (1)               |
| 2       | 500 °C  | 1150 °C | 20 min  | Close manually                     | Closes automatically (1)                   | Closes automatically (0)              |
| 3       | 1150 °C | 1150 °C | 20 min  | -                                  | 0  | 0                                     |
| 4       | 1150 °C | 0 °C    |         | -                                  | 0  | 0                                     |

#### Program 05

Program name: Glaze firing, stoneware ("GLAZE FIRING 1250")

|         |         |         |         | Manual air inlet flap <sup>1</sup> | Semi-automatic air inlet flap <sup>2</sup> | Automatic air inlet flap <sup>3</sup> |
|---------|---------|---------|---------|------------------------------------|--|---------------------------------------|
| Segment | Start   | Target  | Time    | Extra 1                            |  |                                       |
| 1       | 0 °C    | 500 °C  | 180 min | Open manually                      | Open manually (0)                          | Opens automatically (1)               |
| 2       | 500 °C  | 1250 °C | 20 min  | Close manually                     | Closes automatically (1)                   | Closes automatically (0)              |
| 3       | 1250 °C | 1250 °C | 20 min  | -                                  | 0  | 0                                     |
| 4       | 1250 °C | 0 °C    |         | -                                  | 0  | 0                                     |

<sup>1</sup> Air inlet flap us opened and closed manually.

<sup>2</sup> In the case of furnaces with a semi-automatic air inlet flap, the flap is closed when the extra function (Extra 1) is activated.

<sup>3</sup> In the case of furnaces with an automatic air inlet flap, the flap is opened when the extra function (Extra 1) is activated.



#### Note

If one of the programs described above has a higher maximum temperature than that of your furnace, this program will not be preset.

In the case of furnaces with no extra function to close the air inlet flap semi-automatically, the flap can only be opened and closed manually.

## 6.5.2 Bisque Firing

When the greenware is completely dry, it is bisque fired; that is, it is fired in the furnace at between approx. 900 °C and 950 °C. The first firing – for unglazed pottery (terracotta) the only firing – changes the physical and chemical properties of the clay. It becomes "bisque ware" (like a clay brick) and is hard and cannot be dissolved in water.

During the bisque firing the pots in the furnace can touch each other. They can be stacked (also inside each other) as long as they are not too heavy or do not prevent each other from shrinking. Tiles or flat plates should be placed directly on the shelves to prevent distortion. It really depends on the size of the objects whether they are stacked on several shelves or if a few larger pieces fill the entire furnace. But the chamber should not be "overloaded" to ensure sufficient air circulation. For the firing it is important that you know what happens to the pottery. It loses a lot of water and shrinks. If the furnace temperature is raised too quickly, the steam does not have enough time to escape and objects can crack and damage the furnace. Therefore, the furnace should be heated slowly to about 650 °C at approx. 100 °C to 150 °C per hour. Chemically bound water escapes from the clay until about this temperature. From this time you can heat the furnace to the final temperature at full power. Nabertherm controllers handle this task fully automatically.

The controller instruction manual contains all the details.

Because of the large mass and the good insulation, it takes several hours for the furnace to cool; be patient. You should open the lid a little only when the furnace has reached about **100 °C**.

When the furnace is completely open, many people are amazed to find that there have been several changes to the pottery. The pieces are smaller, they are lighter in color, the clay has a different color, the bisque ware is hard and you can now lift a pot by its handle without fear of it breaking off.

## 6.5.3 Glaze Firing

Usually, the glaze firing is the highest temperature firing. The temperature range for earthenware (usually red or brown clay) is about 1040 °C to 1080 °C. For stoneware (usually white clay) the furnace has to reach at least 1200 °C. The glazes must be adapted to suit the temperature range.

The top of the shelves should be painted with a separating agent (batt wash) before a glaze firing. This coating should be renewed from time to time.

Check the areas where the pottery is to stand - they must be free of glaze. Pottery with a glazed base must be placed on stilts or triangular rods for the firing. Glazed pottery should be handled very carefully and should not be touched at the edges. The pots must not touch in the furnace - the glaze would fuse together (there should be a few centimeters between the pots). There must also be a gap of at least 2 cm to the heating elements.

Always use only glazes in one melting range (e.g. 1050 °C) in a firing. Heat the furnace to about 500 °C at reduced power (approx. 180 °C per hour, see also controller instructions) (water escapes from the glaze), and then heat to the final temperature at full power. Hold this temperature for about 30 minutes so that the glaze melts evenly throughout the furnace.

Only open the lid or door when the temperature has dropped to **below 50 °C**. Many glaze cracks are the result of opening the lid too soon.

You can grind any glaze drops on the bottom of the pottery or the shelves with a grinding stone or an angle grinder - paying attention to all the safety regulations.

Do not use very runny glazes to avoid damaging the shelves, the furnace insulation or the heating elements and the furnace itself.

You can obtain firing and glazing accessories and specialist literature from a specialist dealer in your neighborhood. We will be happy to provide you with addresses.

## 6.5.4 Reduction Firing



In a reduction firing, oxygen in the furnace is consumed by means of a foreign substance. However, since oxygen is needed to maintain the protective oxide layer on the heating elements NO reduction firings should be carried out in an electrically heated furnace.

**Under certain circumstances, high concentrations of gases can settle in the insulation and destroy it.**

If it is unavoidable, after each reduction firing the furnace must be fired with a normal atmosphere to replace the protective oxide layer on the heating elements.

**No warranty claims will be accepted for damage caused by reduction firings.**

## 7 Servicing, Cleaning, and Maintenance

### 7.1 Shutting Down the Furnace for Servicing, Cleaning, and Maintenance



#### Risks during normal operation

Repairs and maintenance work must be performed by authorized persons, following the maintenance instructions and the accident prevention regulations. We recommend that the maintenance and repair work be carried out by the service team of Nabertherm GmbH. Non-compliance may cause injuries, death, or considerable damage to property.

**Operators may only rectify faults that are obviously due to malfunctions.**

**Wait until the furnace and the connected parts have cooled to room temperature.**



- The furnace must be completely empty.
- Switch off the main switch **and pull out the power plug.**



#### Risks during normal operation

Do not touch any objects without first checking how hot they are.

### 7.2 Furnace Insulation

The refractory bricks (insulation) are of a particularly high quality. Due to the manufacturing process small holes or cavities may occur. These are quite normal and underline the quality features of the bricks. These holes or cavities are not a reason for complaint.

Repairs to the insulation or the replacement of components in the heating chamber may only be performed by persons who are trained about possible hazards and protective measures and can apply this knowledge without supervision.

**During the work on the insulation or the replacement of components in the furnace chamber, the following points must be observed:**





When repairs are made or demolition work is performed, silicon dust may be released. Depending heat-treated materials contained in the furnace, further contaminants may be contained in the insulation. To exclude possible health risks, dust concentrations must be kept to a minimum during any work performed at or near the insulation. In many countries there are specific occupational safety limits. You can acquire more relevant information by investigating the relevant legal specifications in your country.

Dust concentrations should be kept as low as possible. Dust must be removed using a suction device or a vacuum cleaner with a high-performance filter (HEPA – category H). Strong air currents such as drafts, for example, must be prevented. Pressurized air or brush must not be used for cleaning. Piles of dust must be sprinkled.

During work on the insulation a respirator mask with an FFP2 filter or an FFP3 filter must be used. The work clothing must be loose and cover the body completely. Gloves and goggles must be worn. Soiled clothing should be cleaned before it is removed with a vacuum cleaner equipped with a HEPA filter.

Contact with skin and eyes should be avoided. The impact of fibers on skin or eyes can lead to mechanical irritation which, in turn, causes reddening and itchiness. After completing the work, or after direct contact, the skin must be washed with soap and water. If there is contact with the eyes, they must be washed out carefully for several minutes. If necessary, an eye doctor should be consulted.

Smoking, eating and drinking at the workplace is prohibited.

In Germany, during work involving insulation, the technical rules for hazardous substances must be applied. In particular: TRGS 500, TRGS 521, TRGS 558, TRGS 559, TRGS 900; <http://www.baua.de> (German).

Additional information regarding how to handle fibrous materials can be found at <http://www.ecfia.eu> (English).

When the materials are discarded, national and regional guidelines must be observed. The possible presence of hazardous contaminants generated by the furnace process must be taken into account.



#### Warning – Danger of Electric Shock

Work on the electrical equipment may be done only by qualified, authorized electricians. During work it must be ensured that the furnace and the switching equipment cannot be activated by mistake (pull out the power plug) and that all moving parts in the furnace are secured. Observe DGUV V3 or the corresponding national regulations in the country where the furnace is installed.

Wait until the furnace and the connected parts have cooled to room temperature.

### 7.3 Regular Maintenance of the Furnace

| A   | B                         | C |   |   | D |   |   |   |   | E      |        | F                  |
|---|---------------------------|---|---|---|---|---|---|---|---|--------|--------|--------------------|
|   |                           | 1 | 2 | 3 | D | W | M | Q | Y | X<br>1 | X<br>2 |                    |
| Safety inspection in conformance with DGUV V3 or the corresponding national regulations | Compliant with regulation |   |   |   |   |   |   |   |   |        | •      | for commercial use |

| A   | B   | C |   |   | D |   |   |   |   | E  |    | F |
|---|---|---|---|---|---|---|---|---|---|----|----|---|
|   |   | 1 | 2 | 3 | D | W | M | Q | Y | X1 | X2 |   |
| Contact safety switch<br>(switches the heating off<br>when the lid is opened) | Function check  |   |   | • |   |   |   | • |   |    | •  |   |
| Furnace chamber, vent<br>holes<br>and vent pipes                              | Clean and<br>check for damage,<br>vacuum out carefully  |   |   |   |   |   | • |   |   | •  |    |   |
| Heating elements  | Visual inspection                                       |   |   | • |   |   | • |   |   |    | •  |   |
| Thermocouple  | Visual inspection                                       |   |   | • |   |   |   | • |   | •  |    |   |
| Tensioning straps/Lid<br>tensioning ring                                      | Check and adjust if<br>necessary before every<br>firing |   |   | • | • |   |   |   |   | •  |    |   |
| Lid locks   | Check and adjust if<br>necessary before every<br>firing |   |   | • | • |   |   |   |   | •  |    |   |
| Lid fit (tight closure/fit of<br>the lid)                                     | Check setting and adjust if<br>necessary                |   |   |   |   |   | • |   |   | •  |    |   |

#### Symbols:

**A** = Component / Position / Function / **B** = Measure / **C** = Spare Part Stocks / **D** = Maintenance Interval / **E** = Performed by / **F** = Comment

#### Spare part stocks:

**1** = Stocks urgently recommended  
**2** = Stocks recommended /  
**3** = As required, not relevant

#### Maintenance Interval

**Notice:** If ambient conditions are severe, the maintenance intervals must be shorter.

**D** = Daily, each time before the furnace is started  
**W** = Weekly  
**M** = Monthly /  
**Q** = Quarterly  
**Y** = Yearly /  
• = Check, replace

#### Performed by:

**X1** = Operating personnel  
**X2** = Specialist personnel



#### Warning – Danger of Electric Shock!

Work on the electrical equipment may be done only by qualified, authorized electricians.



#### Notice

Maintenance work must be performed only by authorized persons, observing the maintenance instructions and the accident prevention regulations. We recommend that maintenance and repair work be carried out by the service team of Nabertherm GmbH.

## 7.4 Adjusting the Lid

If the lid does not sit properly on the hinge side when the furnace is cold (this can be seen by a gap between the lid and the collar insulation) the retaining plates (4) of the gas dampers have to be adjusted. Before you make the adjustment, make sure that the lid is closed using the lock (1).

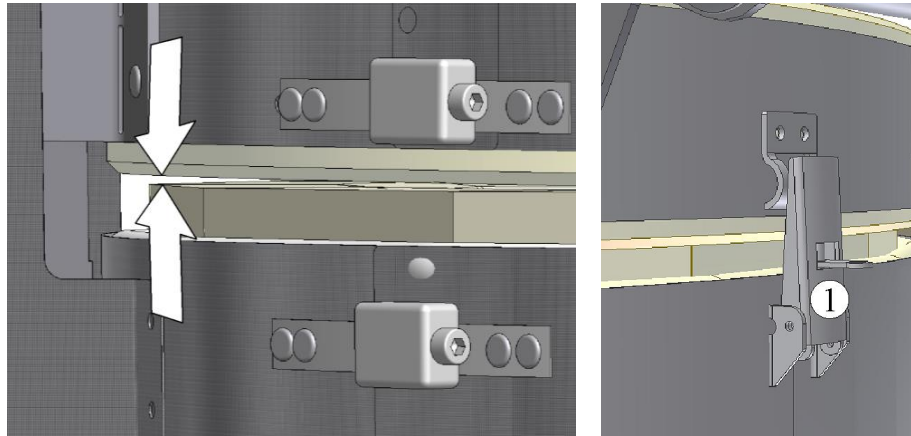

Fig. 34: Lock the lid (similar to picture)

To adjust the lid, unscrew the screws (2) on each side of the switchgear cover using suitable tools. On the hinge side, press the lid down (3) until it sits properly all the way around.

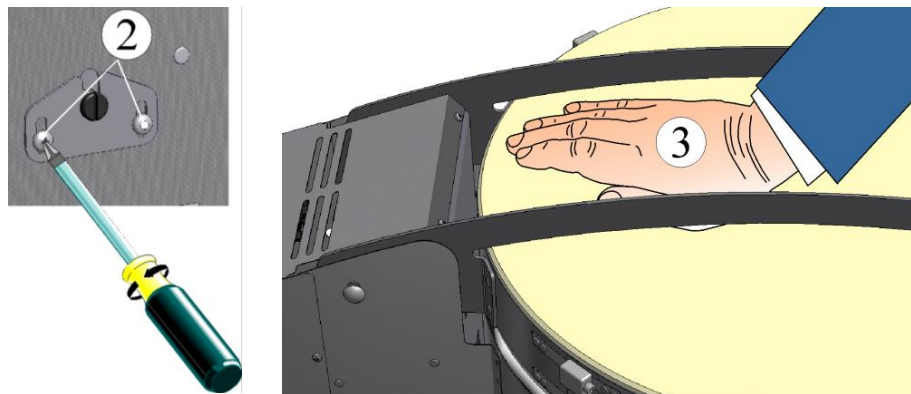

Fig. 35: Loosen retainer plate/press lid down (similar to picture)

Press the retainer plate (4) lightly on the axis of the gas damper and tighten the screws (5) on both sides again.

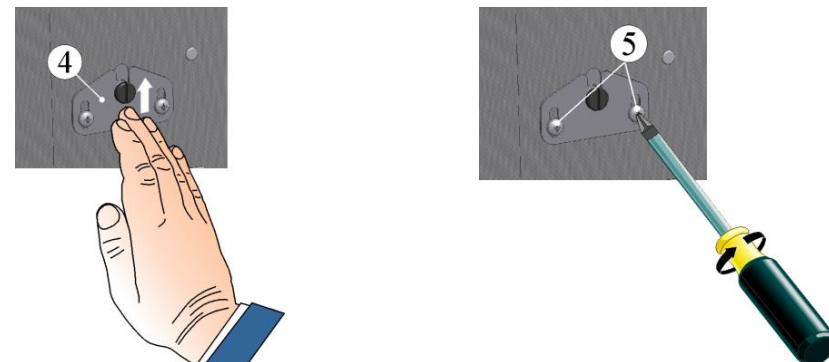

Fig. 36: Press retainer plate down and secure (similar to picture)

## 7.5 Adjusting the Tensioning Straps

Before each firing a check must be made to ensure that the furnace casing and the lid clamp ring retain their firm fit and that the furnace lid still closes snugly. If either the furnace casing or the lid clamp ring is loose, they must be retightened on the outer tensioning straps. Tightening the straps holds the insulation in the furnace lining and the lid in place. Tighten the screws of the furnace casing and/or lid clamp ring with the hex key that is supplied. Secure the tensioning connections against turning with pliers, for example.

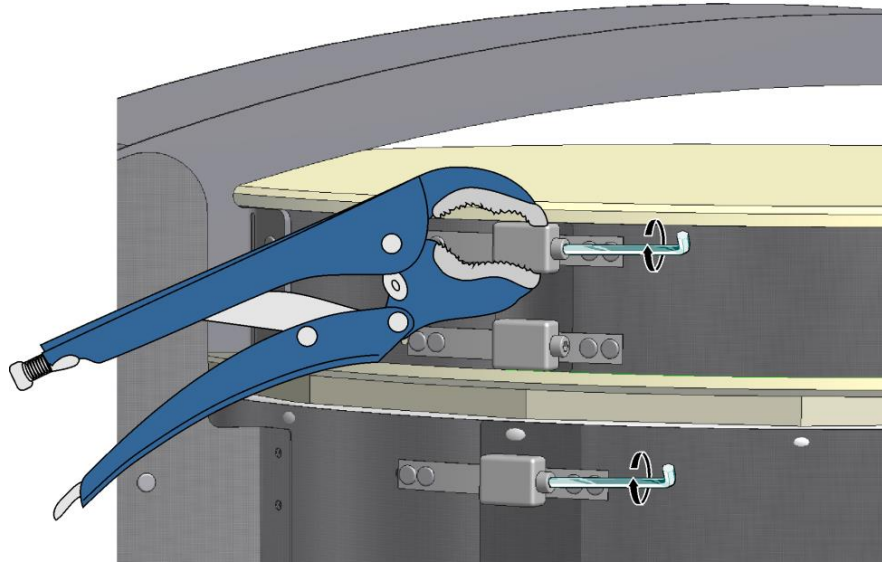

Fig. 37: Adjusting the tensioning straps (similar to picture)

## 7.6 Separate the Snap-In Coupling (Plug) from the Furnace Housing

With a small flat blade screwdriver carefully push the locking latch (2) upward while pulling the plug (3) out of the coupling (4).

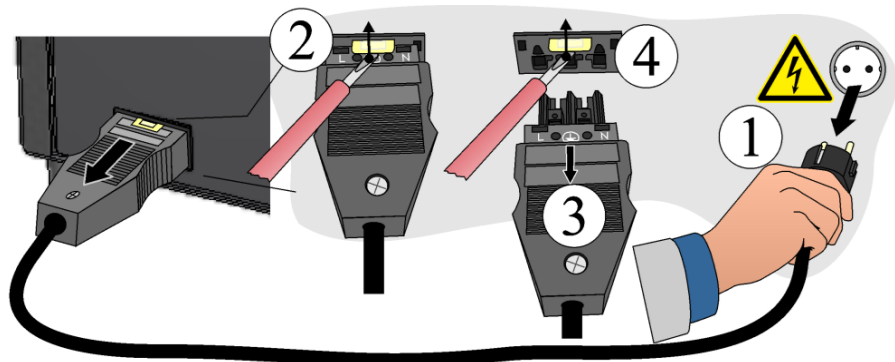

Fig. 38: Separate the snap-in coupling (plug) from the furnace housing (similar to picture)

## 7.7 Cleaning Products



Carry out the procedure to switch off the furnace (see "Operation") Then pull the power plug out of the socket. Allow the furnace to cool naturally.

**Pay attention to the labeling and information on the cleaning product packaging.**

Wipe the surface with a damp, lint-free cloth. You may also use the following cleaning products.

| Component and position             | Cleaning product   |
|------------------------------------|--|
| Metal surface                      | Stainless steel cleaner  |
| Inside                             | Carefully clean with a vacuum cleaner (be careful with the heating elements) |
| Insulation brick (e.g. lid)        | Carefully clean with a vacuum cleaner (be careful with the heating elements) |
| Instrument field on the controller | Wipe the surface with a damp, lint-free cloth (e.g. glass cleaner).          |

Fig. 39: Cleaning product

When you have finished cleaning, completely remove the cleaning product from the surfaces with a moist, lint-free cloth.

After cleaning, check all cables and connections, insulation, heating elements for damage and report faults immediately.



### Note

The furnace, furnace chamber, and connected parts may **NOT** be cleaned with a high-pressure cleaning device.

## 8 Malfunctions

Work on the electrical system may be done only by qualified, authorized electricians. Operators may only rectify malfunctions that are obviously due to operating errors.

Call your local electrician for malfunctions that you cannot localize.

If you have any questions, problems, or requirements, contact Nabertherm GmbH. By mail, phone, or e-mail -> See "Nabertherm Service".

Phone advice is free and non-binding for our customers – all you pay is the phone costs.

In case of mechanical damage, send an email containing the above information and a digital photo of the damaged part and a photo of the complete furnace to the following address: -> see "Nabertherm Service".

If a malfunction cannot be rectified with the described solutions, contact our service hotline directly.

Have the following information at hand when you phone. This makes it easier for our customer service to answer your questions.

## 8.1 Error Messages of the Controller

| ID+ Sub-ID                 | Text                         | Logic   | Remedy  |
|----------------------------|------------------------------|---|---|
| <b>Communication error</b> |                              |   |   |
| 01-01                      | Bus zone                     | Communication connection to a control module disrupted                        | Check that the control module is firmly attached<br>LEDs on the control modules red?<br>Check the cable between the operating unit and the control module.<br>Plug of the connection cable not plugged correctly into the operating unit. |
| 01-02                      | Bus communication module     | Communication connection to the communication module (Ethernet/USB) disrupted | Check that the communication module is firmly attached<br>Check the cable between the operating unit and the communication module.  |
| <b>Sensor error</b>        |                              |   |   |
| 02-01                      | TC open                      |   | Check thermocouple, thermocouple terminals and cable<br>Check contacts of the thermocouple cable in plug X1 on the control module (contacts 1+2)  |
| 02-02                      | Outside TC measurement range |   | Check set thermocouple type<br>Check poles of thermocouple connection   |
| 02-03                      | Compare point error          |   | Control module defective  |
| 02-04                      | Compare point too hot        |   | Temperature in the switchgear too high (approx. 70 °C)<br>Control module defective  |
| 02-05                      | Compare point too cold       |   | Temperature in the switchgear too low (approx. - 10 °C)   |
| 02-06                      | Encoder separated            | Error at the 4-20 mA input of the controller (<2 mA)                          | Check 4-20 mA sensor<br>Check the connection cable to the sensor  |
| 02-07                      | Sensor element defective     | PT100 or PT1000 sensor defective  | Check PT sensor<br>Check connection cable to the sensor (cable break/short circuit)   |
| <b>System error</b>        |                              |   |   |
| 03-01                      | System memory                |   | Error after firmware updates <sup>1)</sup><br>Defective operating unit <sup>1)</sup>  |
| 03-02                      | ADC error                    | Communication between AD converter and controller disrupted                   | Replace control module <sup>1)</sup>  |

| ID+ Sub-ID        | Text                   | Logic   | Remedy  |
|-------------------|------------------------|---|---|
| 03-03             | File system defective  | Communication between display and memory chip disrupted   | Replace operating unit  |
| 03-04             | System monitoring      | Program execution on the operating unit defective (Watchdog)  | Replace operating unit<br>USB flash drive removed too soon or defective<br>Switch controller off and on again   |
| 03-05             | Zone system monitoring | Program execution on a control module defective (Watchdog)  | Replace control module <sup>1)</sup><br>Switch controller off and on <sup>1)</sup>  |
| 03-06             | Self-test error        |   | Contact Nabertherm Service <sup>1)</sup>  |
| <b>Monitoring</b> |                        |   |   |
| 04-01             | No heating power       | No temperature increase in the ramps when heating output $\leq$ 100 % for 12 minutes and when the temperature setpoint is higher than the current furnace temperature   | Acknowledge the error (if necessary disconnect from the power supply) and check safety contactor, door switch, heating controls and controller.<br>Lower D value of the control parameters.   |
| 04-02             | Excess temperature     | The temperature of the control zone exceeds the max. program setpoint or the maximum furnace temperature by 50 Kelvin (from 200 °C)<br>The equation for the switch off threshold is:<br>Maximum program setpoint + zone offset of the master zone + charge control offset [Max] (if charge control active) + excess temperature switch-off threshold (P0268, e.g. 50 K) | Check solid state relay<br>Check thermocouple<br>Check controller   |
|                   |                        | A program was started at a furnace temperature higher than the maximum setpoint in the program  | Do not start the program until the furnace temperature is lower. If this is not possible, insert a hold time as a start segment and then a ramp with the desired temperature (STEP=0 minutes duration for both segments)<br>Example:<br>700 °C -> 700 °C, Time: 00:00<br>700 °C -> 300 °C, Time: 00:00<br>The normal program begins here<br>From Version 1.14, the actual temperature is considered at the start. |
| 04-03             | Power failure          | The set limit for restarting the furnace was exceeded   | If possible, use an uninterruptible power supply  |
| 04-04             | Alarm                  | A configured alarm was triggered  |   |

| ID+ Sub-ID | Text                     | Logic   | Remedy   |
|------------|--------------------------|---|--|
| 04-05      | Self optimization failed | The determined values are implausible   | Do not carry out self optimization at the lower temperature range of the furnace working range |
|            | Battery weak             | Time is not shown correctly. A power failure may not have been handled properly | Export all parameters to a USB flash drive<br>Replace the battery (see “Specifications”)       |

Error messages can be reset by pressing **twice** the jog dial . If there is another error message, contact Nabertherm Service. Recirculation motors (if included) also remain switched on in case of an error until the temperature falls below the set cut-off temperature.

## 8.2 Warnings of the Controller

Warnings are not displayed in the error archive. They are only displayed on the display and in the file of the parameter export. Warning do not generally lead to a program crash.

| No. | Text                                 | Logic   | Remedy  |
|-----|--------------------------------------|---|---|
| 00  | Gradient monitoring                  | The limit value of the configured gradient monitoring was exceeded                          | For troubleshooting, refer to “Gradient Monitoring”<br>Gradient set too low   |
| 01  | No control parameters                | No “P” value was entered for the PID parameters   | Enter at least one “P” value in the control parameters. It must not be “0”  |
| 02  | Charge thermocouple defective        | No charge thermocouple was determined with the current program and activated charge control | Plug in a charge thermocouple<br>Disable charge control in the program<br>Check the charge thermocouple and its cable for damage  |
| 03  | Cooling thermocouple defective       | The cooling thermocouple is not plugged in or is defective                                  | Plug in a cooling thermocouple<br>Check the cooling thermocouple and its cable for damage<br><br>If there is a malfunction in the cooling thermocouple during active controlled cooling, the system switches over to the thermocouple of the master zone. |
| 04  | Documentation thermocouple defective | Either no documentation thermocouple or a defective one was determined.                     | Plug in a documentation thermocouple<br>Check the documentation thermocouple and its cable for damage   |
| 05  | Power failure                        | A power failure was determined.<br>There was no program interrupt                           | None  |
| 06  | Alarm 1 - Band                       | The configured band alarm 1 was triggered   | Optimize the control parameters<br>Alarm set to narrowly  |
| 07  | Alarm 1 - Min                        | The configured min. alarm 1 was triggered   | Optimize the control parameters<br>Alarm set to narrowly  |



| No. | Text   | Logic   | Remedy  |
|-----|--|---|---|
| 08  | Alarm 1 - Max  | The configured max. alarm 1 was triggered   | Optimize the control parameters<br>Alarm set to narrowly  |
| 09  | Alarm 2 - Band   | The configured band alarm 2 was triggered   | Optimize the control parameters<br>Alarm set to narrowly  |
| 10  | Alarm 2 - Min  | The configured min. alarm 2 was triggered   | Optimize the control parameters<br>Alarm set to narrowly  |
| 11  | Alarm 2 - Max  | The configured max. alarm 2 was triggered   | Optimize the control parameters<br>Alarm set to narrowly  |
| 12  | Alarm - External   | The configured alarm 1 at input 1 was triggered   | Check the source of the external alarm  |
| 13  | Alarm - External   | The configured alarm 1 at input 2 was triggered   | Check the source of the external alarm  |
| 14  | Alarm - External   | The configured alarm 2 at input 1 was triggered   | Check the source of the external alarm  |
| 15  | Alarm - External   | The configured alarm 2 at input 2 was triggered   | Check the source of the external alarm  |
| 16  | No USB flash drive inserted                                      |   | When exporting data, insert a USB flash drive in the controller   |
| 17  | Import/export of data via the USB flash drive unsuccessful       | The file was edited with a PC (text editor) and saved in the wrong format or the USB flash drive was not detected.<br><br>You want to import data that is not in the import folder on the USB flash drive | Do not edit XML files with a text editor, only in the controller.<br>Format the USB flash drive (format: FAT32). No quick formatting<br>Use a different USB flash drive (1-8GB)<br>When importing, all data must be in the import folder on the USB flash drive.<br>It is best to use USB flash drives up to 8GB. |
|     | Programs are rejected during the import of programs              | Temperature, time or rate is outside the limit values   | Import only programs that are suitable for the furnace. The controllers differ as regards the number of programs and segments and the maximum furnace temperature.  |
|     | While programs are being imported, "Error occurred" is displayed | The complete parameter set (at least the configuration files) was not stored in the "Import" folder on the USB flash drive  | If you deliberately left out files during import, ignore the message. Otherwise, check the completeness of the import files.  |
| 18  | "Heating blocked"  | This message is displayed if a door switch is connected to the controller and the door is open  | Close the door<br>Check the door switch   |

### 8.3 Malfunctions of the Switchgear

| Error  | Cause   | Remedy  |
|--|---|---|
| <b>Controller does not light up</b>                                      | Controller is switched off  | Switch the power switch to "T"  |
|  | No power available  | Is the power cord plugged into the socket?<br>Check the building fuses.<br>Check the fuse of the controller (if present) and replace it if necessary. |
|  | Check the fuse of the controller (if present) and replace it if necessary.  | Switch the power switch on. If the error occurs again, contact Nabertherm Service   |
| <b>Controller displays error</b>   | See the separate instructions of the controller   | See the separate instructions of the controller   |
| <b>Furnace does not heat</b>   | Door / cover is open  | Close the door / cover  |
|  | The door contact switch is faulty (if present)  | Check the door contact switch   |
|  | The "wait" or clock icon (product line 400 controllers) lights up   | The program is waiting for the programmed start time.<br>Set the wait time to 00:00 or disable it   |
|  | Error in entering the program   | Check the heating program (see the separate instructions of the controller)   |
|  | Heating element defective   | Have this checked by Nabertherm Service or a qualified electrician.   |
| <b>Very slow heating of the heating space</b>                            | The fuse(s) of the connection is/are defective.   | Check the fuse(s) of the connection and replace if necessary.<br>Notify Nabertherm service if the new fuse fails again immediately.                   |
| <b>The program does not jump to the next segment</b>                     | In one TIME segment in the program input, the wait time is set to INFINITE (product line 400 controllers).<br>If charge control is activated, the temperature of the charge is higher than the zone temperatures. | Do not set the wait time to INFINITE  |
|  | If charge control is activated, the temperature of the charge is higher than the zone temperatures.   | The parameter [LOWER BLOCK] must be set to [NO].  |
| <b>The controller module can not be registered on the operating unit</b> | Addressing error (product line 400 controllers)   | Perform a bus reset   |
| <b>The controller is not heating in the optimization</b>                 | No optimization temperature has been set  | The temperature to be optimized must be entered (see the separate instructions of the controller)   |

|   |   |   |
|---|---|---|
| <p><b>The temperature rises faster than the controller setting allows</b></p> | <p>The switch element of the heating unit (semiconductor relay, thyristor or switch contactor) is defective.</p> <p>Individual defective components inside a furnace cannot be completely ruled out in advance. That is why the controllers and the switchgear units must be equipped with safety facilities. For example, the furnace shuts down the heating unit in response to error message 04 - 02 via an independent contact element.</p> | <p>Have the switch element tested by a qualified electrician and replaced as necessary.</p> |
|---|---|---|

### 8.4 Controller Check List

|  |  |
|--|--|
| <p><b>Customer:</b></p>  |  |
| <p><b>Furnace model:</b></p>   |  |
| <p><b>Controller model:</b></p>  |  |
| <p><b>Controller version (see information menu ⓘ):</b></p>               |  |
| <p><b>Controller serial number</b></p>                                   |  |
| <p><b>Furnace serial number</b></p>                                      |  |
| <p><b>Error code in the display:</b></p>                                 |  |
| <p><b>The following errors are dependent on external influences:</b></p> | <p>02-05 Ambient temperature too low: &lt; -10 °C (14 °F)<br/>02-04 Ambient temperature too high: &gt; 70 °C (158 °F)</p>  |
| <p><b>Detailed error description:</b></p>                                |  |
| <p><b>Export of the service information:</b></p>                         | <p>Please export all the data to a USB stick using the function [EXPORT COMPLETELY] Generate a zip file using the ZIP function integrated in Windows (compression) of the exported folder (see the section "Importing and Exporting Data and Parameters") and send them to your contact at Nabertherm Service.</p> |
| <p><b>When does this error occur?</b></p>                                | <p>At specific point in the program or at certain times of day:</p> <p>At specific temperatures:</p>   |
| <p><b>How long has the error existed?</b></p>                            | <p><input type="checkbox"/> Error is new</p>   |

|                               |   |  |                             |
|-------------------------------|---|--|-----------------------------|
|                               |   | <input type="checkbox"/> Error has existed for a long time |                             |
|                               |   | <input type="checkbox"/> Unknown                           |                             |
| <b>Error frequency</b>        |   | <input type="checkbox"/> Error occurs frequently           |                             |
|                               |   | <input type="checkbox"/> Error occurs regularly            |                             |
|                               |   | <input type="checkbox"/> Error occurs rarely               |                             |
|                               |   | <input type="checkbox"/> Unknown                           |                             |
| <b>Substitute controller:</b> | Has a substitute controller already been used?                                      | <input type="checkbox"/> yes                               | <input type="checkbox"/> no |
|                               | Did the error continue with the substitute controller?                              | <input type="checkbox"/> yes                               | <input type="checkbox"/> no |
|                               | Checked according to the error search list (see the furnace operating instructions) | <input type="checkbox"/> yes                               | <input type="checkbox"/> no |

Please enter the following test program so that the furnace heats up at full power:

| Program point                  | Value      |
|--------------------------------|------------|
| Segment 01- Start Temperature  | 0 °C       |
| Segment 01- Target Temperature | 500 °C     |
| Segment 01- Time               | 30 minutes |
| Segment 01- Target Temperature | 500 °C     |

Close door/lid and start the example program

Please check the following items:

- Does the furnace heat (temperature rise)?
- Is the "Heating" symbol displayed?

Please call up the information menu in the heating up phase for further details.

**Date:** \_\_\_\_\_ **Name:** \_\_\_\_\_ **Signature:** \_\_\_\_\_

## 9 Spare Parts/Wearing Parts



### Ordering Spare Parts:

Our Nabertherm Service team is available worldwide. Due to our high vertical range of manufacture, we deliver most spare parts from stock overnight or can produce them with short delivery times. You can order Nabertherm spare parts directly from the factory quickly and easily. If you do not find the spare part you are looking for in the spare parts list or in the separate spare parts list, we would be happy to help you. Spare parts can be ordered in writing, by phone or on the Internet -> see "Nabertherm Service".

### Availability of Spare Parts and Wearing Parts:

Although Nabertherm has many spare parts and wearing parts in stock, we cannot guarantee the short-term availability of all of them. We recommend that certain parts be ordered in good time. If you need any assistance when selecting spare parts and wearing parts, the staff at Nabertherm will be glad to help you.



#### Note

Original parts and Accessories are designed especially for Nabertherm furnaces. Replace parts only with original Nabertherm parts. Otherwise the warranty will be void. Nabertherm accepts absolutely no liability for damage caused by using parts that are not original Nabertherm parts.



#### Note

Contact our Nabertherm Service for dismantling and installing wearing/spare parts. See "Nabertherm Service". Work on the electrical equipment may be done only by qualified, authorized electricians. This applies also to repairs that are not described here.

Provide the following details from the type plate:

|   |   |   |
|---|---|---|
| <br><small>MORE THAN HEAT 30-3000 °C</small>   |   |   |
| Nabertherm GmbH<br>Bahnhofstr. 20, 28865 Lilienthal/Bremen, Germany<br>Tel +49 (04298) 922-0, Fax +49 (04298) 922-129<br>contact@nabertherm.de<br><small>www.nabertherm.com</small> |   |   |
| ①   | ② | ④ |
| ③   |   |   |
|   |   |   |
|    |   |   |

- ① Furnace model
- ② Serial number
- ③ Article number
- ④ Year of construction

Fig. 40: Example (type plate)

### 9.1 Replacing a Heating Element



#### Warning – Danger of Electric Shock

Work on the electrical equipment may be done only by qualified, authorized electricians. During work it must be ensured that the furnace and the switching equipment cannot be activated by mistake (pull out the power plug) and that all moving parts in the furnace are secured. Observe DGUV V3 or the corresponding national regulations in the country where the furnace is installed.

Wait until the furnace and the connected parts have cooled to room temperature.



### Warning – General Hazards!

If installed improperly, functioning and safety of the system can no longer be guaranteed. The connection must be properly installed and put into operation by qualified personnel.



### Caution – Damage to Components!

Heating elements are extremely sensitive to breaking. Any strain on or rotation of the heating elements must be avoided. Failure to observe this rule will lead to the immediate destruction of the sensitive heating elements.

Use an appropriate tool to remove the screws all around the cover and keep them in a secure place for later use. The cover must be lowered onto a soft material (such as foam rubber). The number and position of the screws may differ from one furnace model to the next. The furnace may look different than the picture depending on the furnace model and additional equipment.

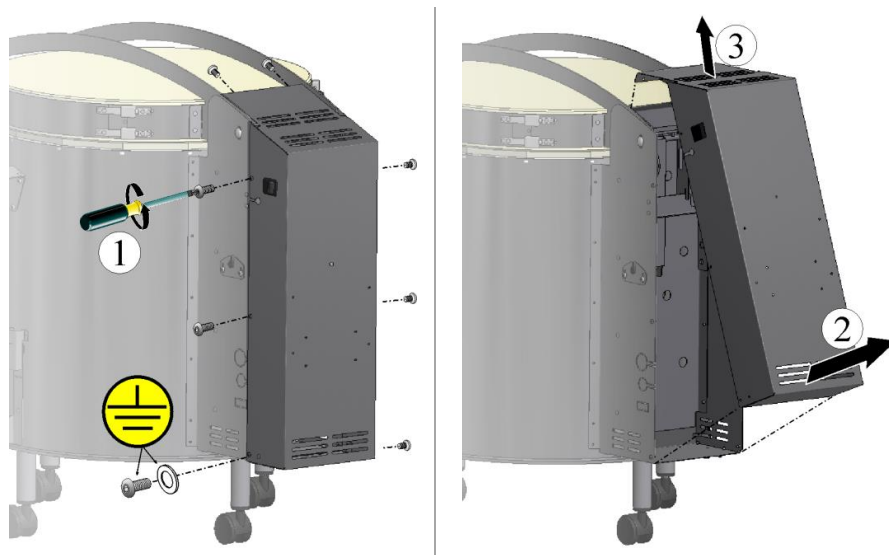

Fig. 41: Dismantle the cover of the switchgear from the back of the furnace (similar to picture)

To replace the heating elements, completely open the lid of the furnace (see "Opening and Closing the Lid").

**Tip:** Because we build many different furnace models, we recommend that you take several photos of the installed heating elements and the switchgear. That simplifies subsequent installation and wiring of new heating elements.

### Removing the heating elements

Unscrew the screws (1) of the connection terminals (2). Place the screws and the connection terminal in a safe place so that they can be reused. So as not to damage the connection terminal or the ceramic feedthrough tube we recommend the use of a suitable pipe wrench (example) as a brace when unscrewing the screws of the connection terminal (5).

**Warning:** The wire have pointed ends that can cause injuries.

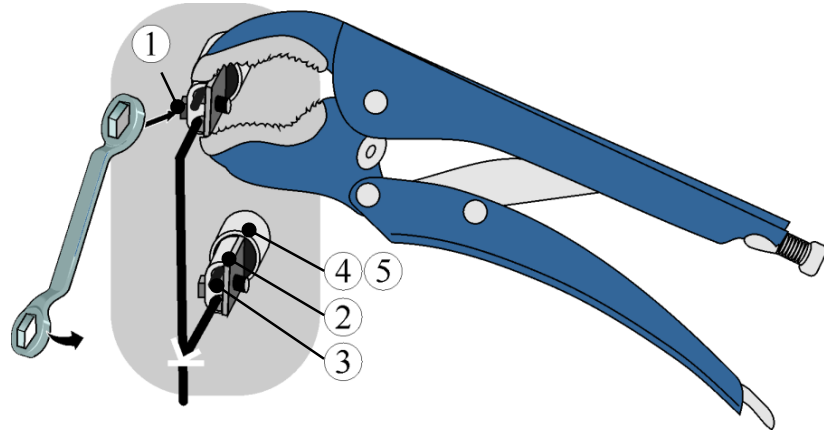

1 Hexagonal screw / 2 Connectional terminal / 3 Heating element end  
 4 Ceramic feedthrough tube / 5 Fiber wadding

Fig. 42: Unscrew the screws on the ends of the heating elements (similar to picture)

Pull the ceramic feedthrough tube out and keep it in a safe place so that it can be used again (replace if included in the spare parts delivery).

Carefully pull out the ends of the heating elements (3) from inside the furnace.

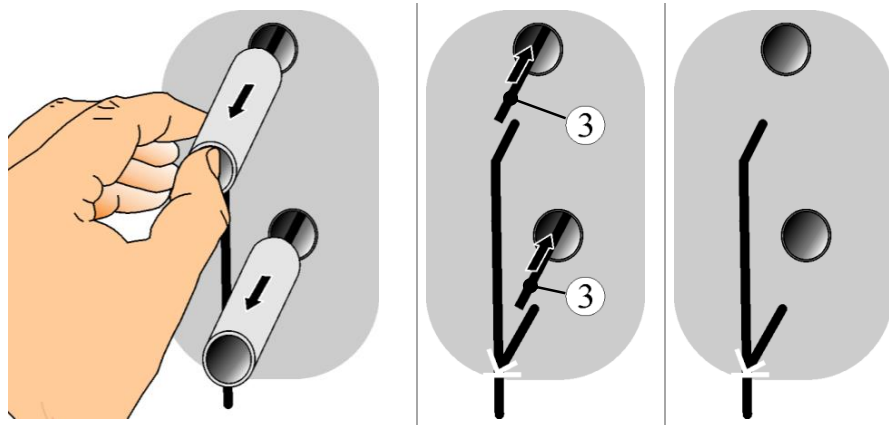

Fig. 43: Carefully remove the ceramic feedthrough tube (similar to picture)

Before you pull the heating element out from inside or carefully and slowly unwind it, remove all fasteners (1) with long-nose pliers (example). When unwinding the heating element, make sure that the insulation brick is not damaged. Caution: Old heating elements are very brittle.

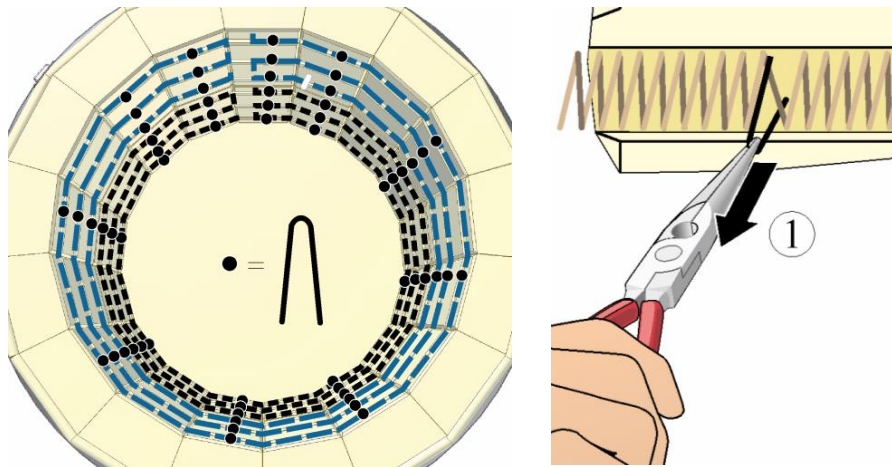

Fig. 44: Carefully remove the fasteners (similar to picture)

### Installing the Heating Elements

Before installing heating elements, we recommend that you clean the furnace chamber thoroughly, with a vacuum cleaner, for example.

The (twisted) ends of the heating elements have a loop as protection. Pinch off the loop with a suitable tool (pliers, for example) before installation.

**Warning:** The wire have pointed ends that can cause injuries.

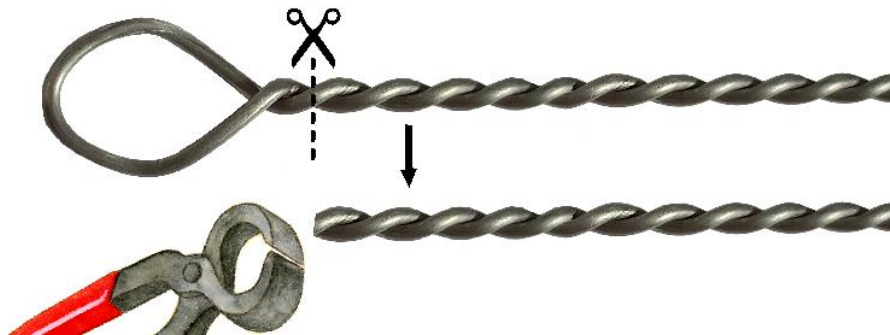

Fig. 45: Pinch off the loop on the end of the heating element (similar to picture)

Check the supplied heating elements for damage before installation.

Compare the delivered items with the delivery note and the purchase order documents.

**Immediately** notify the carrier and Nabertherm GmbH of any missing or damaged parts, as complaints received at a later date cannot be acknowledged.

Carefully place heating elements on a soft surface, as shown below, and, if possible, compare them with the dismantled heating elements. The length and coiling of some furnace models differ.



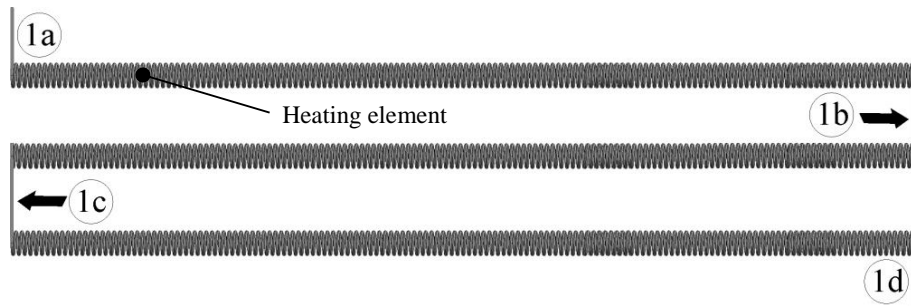

Fig. 46: Heating element (similar to picture)

**Example:**

First, insert the end of the heating element (1a) into the intended opening from inside (this is the opening that you pulled the previous heating element end out of).

Place the heating coil carefully into the intended groove/s. Carefully press the heating element connections (1b and 1c) into the intended slit. Insert the end of the heating element (1d) into the intended opening from inside to outside.

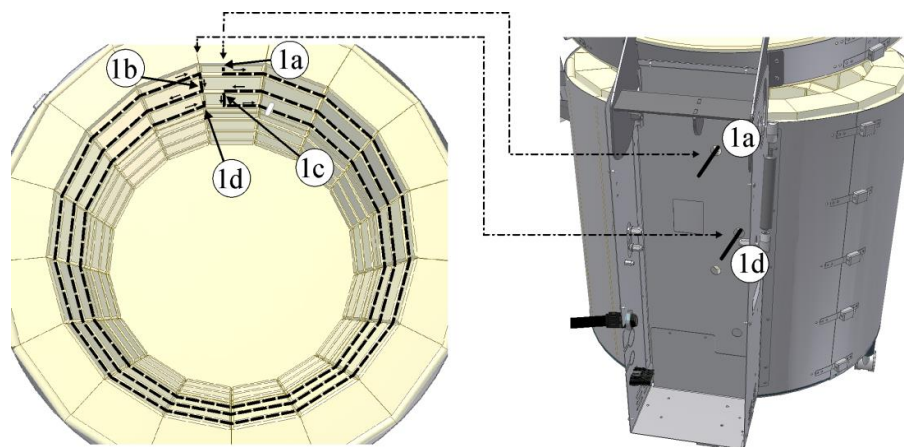

Fig. 47: Place the heating coil in the groove/s (similar to picture)

If available, assemble and place more heating elements in the intended grooves (depending on furnace model).

**Example:**

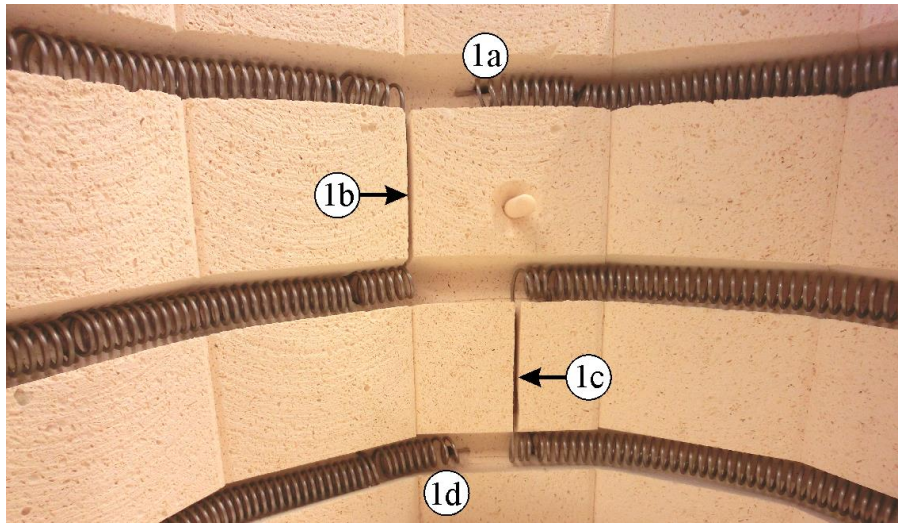

Fig. 48: Place the heating element in the groove/s (similar to picture)

Insert the supplied fasteners into the wall brickwork. They are needed to prevent the heating elements lifting out of the groove when they get hot.

**Notice:** Do not insert fasteners in holes of previous fasteners. We recommend that new fasteners are inserted 2 to 3 cm from existing holes.

**Note:** Distance X of the supplied fasteners must not be changed.

X ~ 14 mm

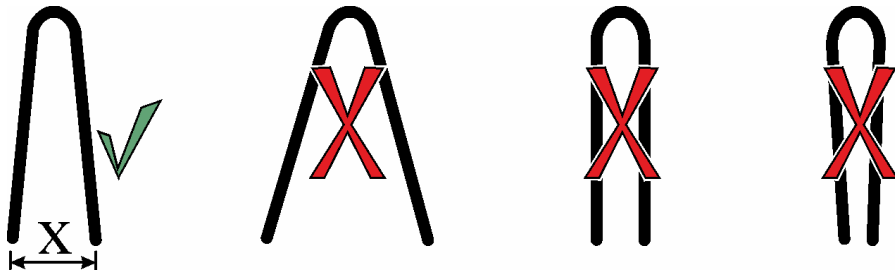

Expand the heating element a little (1) at the position where a cramp will be inserted using a suitable slot screwdriver.

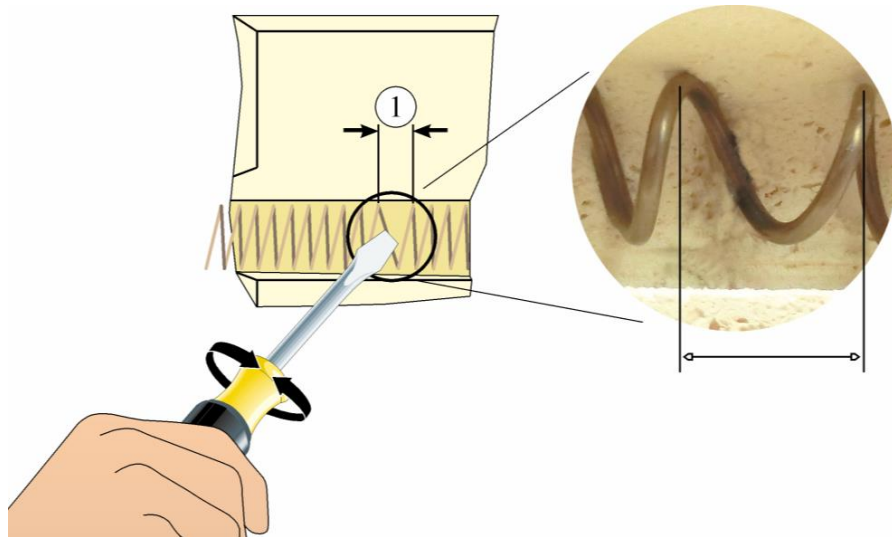

Fig. 49: Spread the heating coil a little (similar to picture)

Position the fasteners in the straight wall (3) of the groove to ensure that the heating element sits properly and functions as intended. After assembly, check that heating element and fastener are positioned correctly



X = ~14 mm

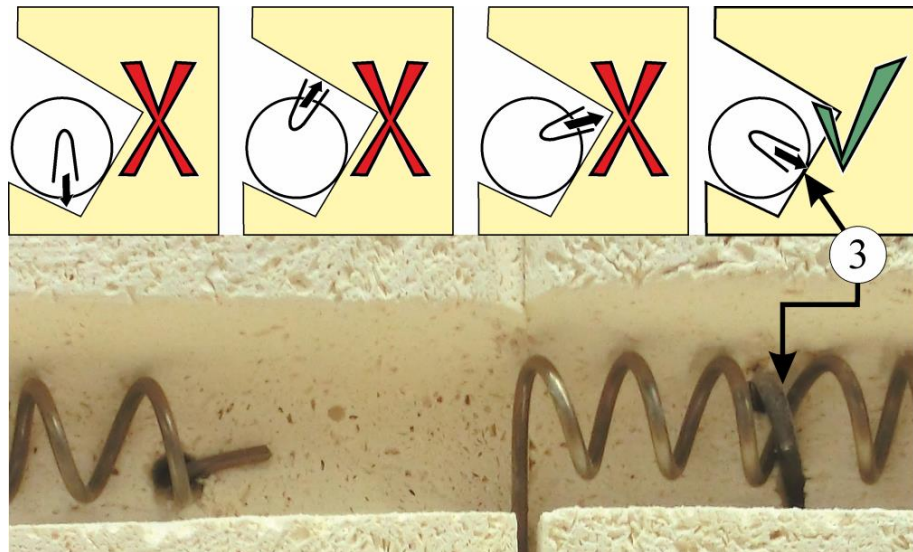

Fig. 50: Correct positioning of the fasteners (similar to picture)

Use a suitable tool to tap the supplied fasteners carefully into the insulating brick until the heating element sits completely on the brickwork. Make sure that the insulation brick is not damaged.

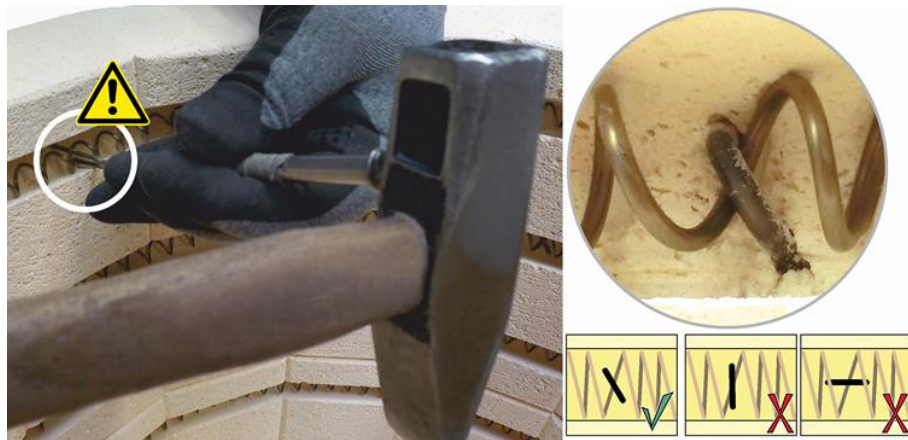

Fig. 51: Tapping the fasteners into the insulation bricks (similar to picture)

Seal the gaps in the ceramic feedthrough tube with a small amount of fiber wadding (included with delivery). To do this, spread the fiber wadding around the end of the heating element with a small screwdriver (1) and press this to the back of the small feedthrough hole. Do not use too much fiber wadding so that the ceramic feedthrough tube (2) can still be inserted until it engages.

Slide the ceramic feedthrough tube (2) on to the ends of the heating elements until they engage.

Slide the connection terminals (3) until they touch the ceramic feedthrough tube.

Use the terminals to create technically correct electrical connections (4).

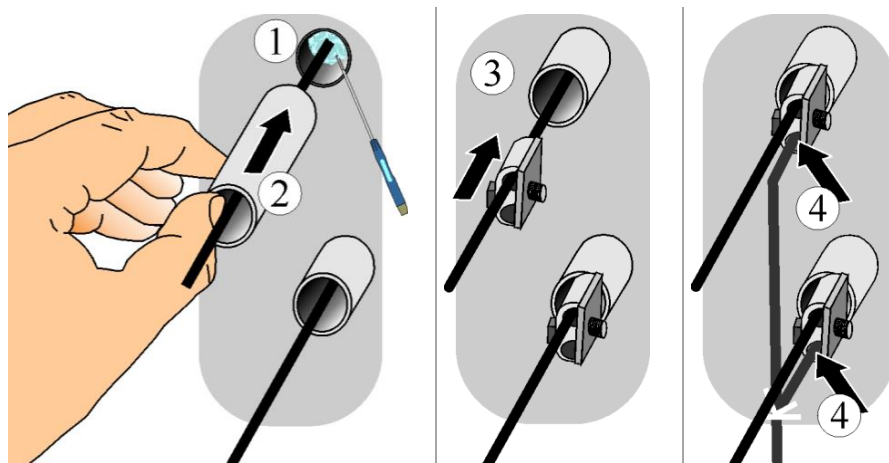

Fig. 52: Seal and insert the ceramic feedthrough tube (similar to picture)

Tighten the screws (5) of the connection terminals (the correct tightening torque can be found in the table below). So as not to damage the connection terminal or the ceramic feedthrough tube we recommend the use of a suitable pipe wrench (example) as a brace when tightening the screws of the connection terminal (5).

**Note:** Tighten all screws on the connection terminals after one week of operation and then once each year. Avoid all stress or twisting of the heating element. If this advice is not followed, the heating elements may be damaged.

Shorten the projecting twisted heating element ends with suitable pincers (6). We recommend that you leave approx. 0.5 cm between the edge and the connection terminal.

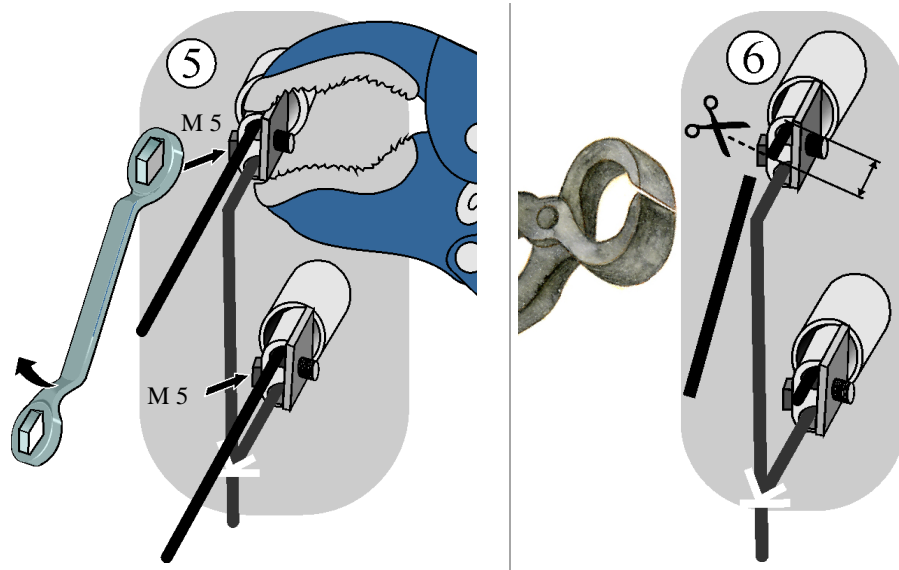
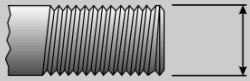



Fig. 53: Tighten the bolts and shorten the projecting heating element ends (similar to picture)

| Screw tightening torque  |  |
|--|--|
| Tighten power cable clamps and screws on the <b>heating elements</b> with a defined torque. If this advice is not followed, the heating elements may be damaged. |  |
| Thread diameter<br>Metric thread (M)   | Torque in Nm   |
|   |  |
| M 4  | 2.0  |
| M 5  | 6.0  |
| M 6  | 8.0  |
| M 7  | 14.0   |
| M 8  | 20.0   |
| M 10   | 39.0   |



**Note**

Make sure that all screwed and plugged connections are in working order.

We recommend that you clean the switchgear and furnace chamber thoroughly, with a vacuum cleaner, for example.

The switchgear cover is assembled in the reverse order.



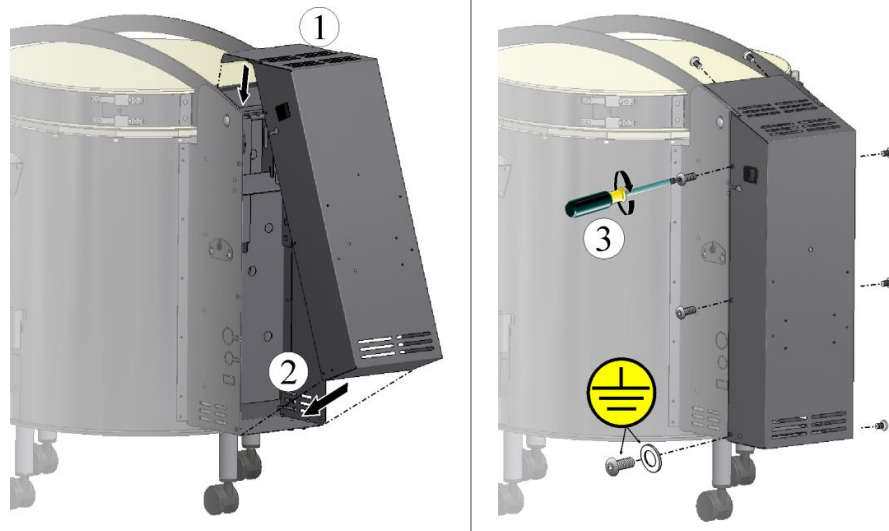

Fig. 54: Assembling the switchgear cover (similar to picture)

### Commissioning

Insert the mains power connector (see chapter "Connection to the Mains Electricity"), then switch on the power switch and check the function of the furnace (see chapter "Operation").

## 9.2 Replacing a Thermocouple



### Warning – Danger of Electric Shock

Work on the electrical equipment may be done only by qualified, authorized electricians. During work it must be ensured that the furnace and the switching equipment cannot be activated by mistake (pull out the power plug) and that all moving parts in the furnace are secured. Observe DGUV V3 or the corresponding national regulations in the country where the furnace is installed.

Wait until the furnace and the connected parts have cooled to room temperature.



### Warning – General Hazards!

If installed improperly, functioning and safety of the system can no longer be guaranteed. The connection must be properly installed and put into operation by qualified personnel.



### Caution - damage to components!

Thermocouples are extremely sensitive to breakage. Any strain on or rotation of the thermocouples must be avoided. Failure to observe this rule will lead to the immediate destruction of the sensitive thermocouples.

Use an appropriate tool to remove the screws all around the cover and keep them in a secure place for later use. The cover must be lowered onto a soft material (such as foam rubber). The number and position of the screws may differ from one furnace model to the next. The furnace may look different than the picture depending on the furnace model and additional equipment.

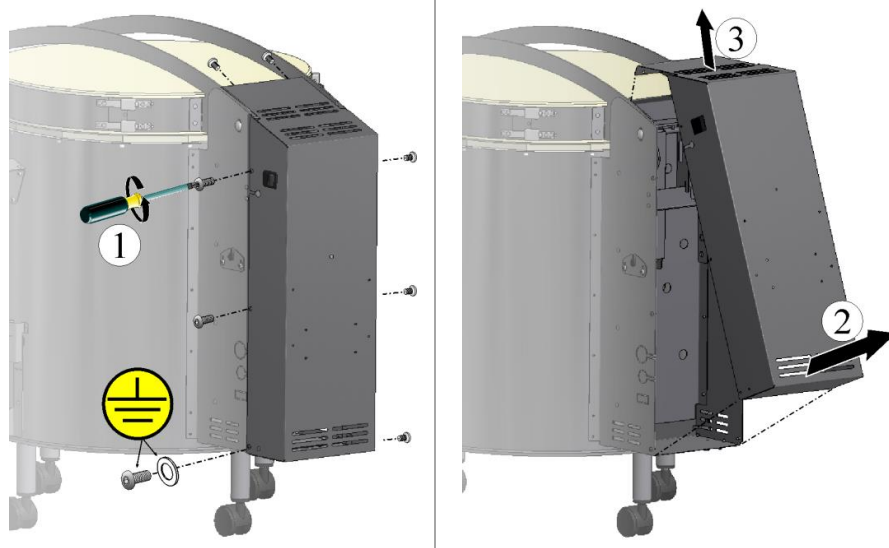

Fig. 55: Dismantle the cover of the switchgear from the back of the furnace (similar to picture)

First remove the two screws (A) from the thermocouple connection. Remove screw (B) and pull out the thermocouple (C).

Insert the new thermocouple carefully into the thermal channel (C), install and connect in reverse order. Make sure that the polarity of the electrical connections (D) is correct\*).

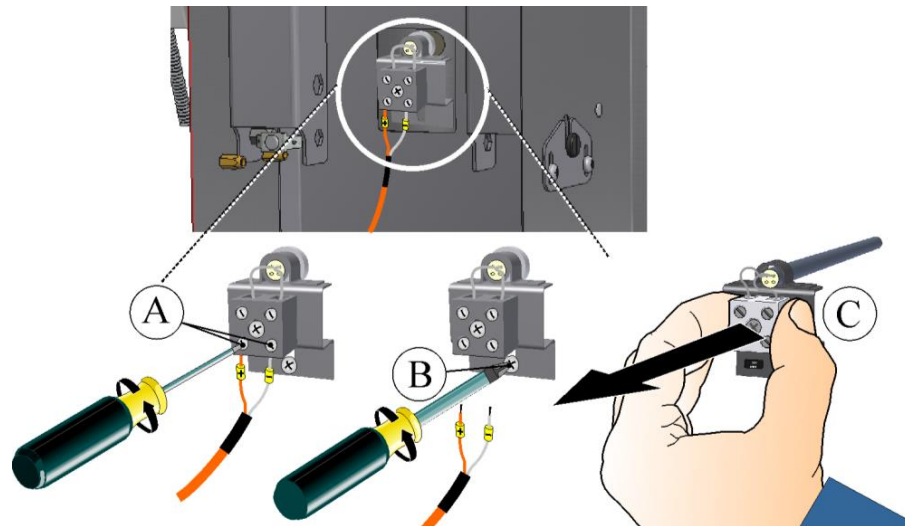

Fig. 56: Removing the thermocouple(s) (similar to picture)



**Note**

\*) The connections of the connecting lines from the thermocouple to the controller are labeled with  $\oplus$  and  $\ominus$ . It is absolutely essential to observe the correct polarity.

$\oplus$  to  $\oplus$        $\ominus$  to  $\ominus$

**Note**

Make sure that all screwed and plugged connections are in working order.

The switchgear cover is assembled in the reverse order.

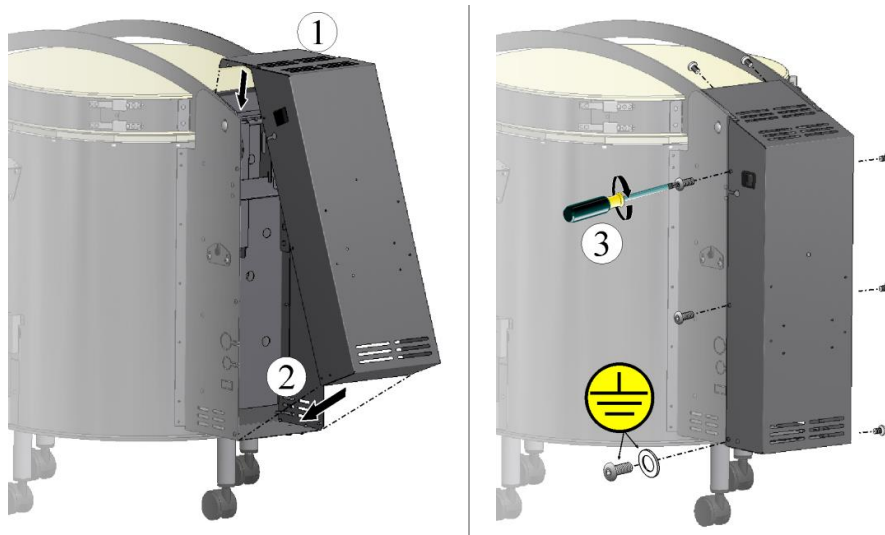



Fig. 57: Assembling the switchgear cover (similar to picture)



**Commissioning**

Insert the mains power connector (see chapter "Connection to the Mains Electricity"), then switch on the power switch and check the function of the furnace (see chapter "Operation").

**10 Accessories (Options)**

| Furnace Furniture/Shelves        |                   |             |   |
|----------------------------------|-------------------|-------------|---|
| Furnace model top loader Top ... | Dimensions in mm  | Part number | Figure  |
| Top 16/R                         | Ø225x10           | 691600954   |   |
| Top 45 .../Top 60                | Ø350x10           | 691600397   |   |
| Top 80 .../Top 100               | Ø420x10           | 691600440   |  |
| Top 130                          | Ø520x10           | 691600...   |   |
| Top 140                          | Ø470x10           | 691600833   |   |
| Top 160 .../Top 190 ...          | Ø520x15           | 691600834   |   |
| Top 220                          | 550x440x18 (R275) | 691601125   |  |

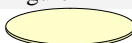
| Furnace Furniture/Shelves             |                  |             |   |
|---------------------------------------|------------------|-------------|---|
| Furnace model fusing top loader F ... | Dimensions in mm | Part number | Figure  |
| F 30                                  | Ø350x10          | 691600397   |  |
| F 75 ...                              | 550x440x18       | 691604219   |  |
| F 110/F 220                           | R275x440         | 691601125   |  |



| Furnace Furniture/Shelves       |                  |             |        |
|---------------------------------|------------------|-------------|--------|
| Furnace model top loader HO ... | Dimensions in mm | Part number | Figure |
| HO 70                           | 340x370x13       | 691600181   |        |
| HO 100                          | 390x400x15       | 691600182   |        |

| Furnace Furniture/Props                  |                  |             |        |
|--|------------------|-------------|--------|
| Furnace models Top ..., F ... and HO ... | Dimensions in mm | Part number | Figure |
| Prop                                     | Ø40x50           | 691600185   |        |
| Prop                                     | Ø40x100          | 691600951   |        |

| Base Extension               |                   |             |        |
|------------------------------|-------------------|-------------|--------|
| Furnace model top loader Top | Dimensions in mm  | Part number | Figure |
| Top 45 ...                   | Height 132        | 401010088   |        |
| Top 60 ...                   | (without castors) |             |        |

| Base Extension                        |                                 |             |        |
|---------------------------------------|---------------------------------|-------------|--------|
| Furnace model fusing top loader F ... | Dimensions in mm                | Part number | Figure |
| F 75 ...                              | Height 132<br>(without castors) | 601402652   |        |
| F 100                                 | Height 132<br>(without castors) | 601402501   |        |

## 11 Electrical Connection (Circuit Diagram)



### Note

The documents included do not always contain the electrical schematics and pneumatic diagrams.

If you need the respective diagrams, they can be ordered from Nabertherm Service.

## 12 Nabertherm Service



The Nabertherm Service team is available at all times for furnace maintenance and repair. If you have any questions, problems, or requirements, contact Nabertherm GmbH. By mail, phone, or the Internet.



### Mail

Nabertherm GmbH  
Bahnhofstrasse 20  
28865 Lilienthal/Germany



### Phone or fax

Phone: +49 (4298) 922-0  
Fax: +49 (4298) 922-129



### Web or e-mail

www.nabertherm.com  
contact@nabertherm.de

**When you contact us, please have the type plate details of the furnace or controller at hand.**

Provide the following details from the type plate:

|  |   |   |
|--|---|---|
| <br>Nabertherm GmbH<br>Bahnhofstr. 20, 28865 Lilienthal/Bremen, Germany<br>Tel +49 (04298) 922-0, Fax +49 (04298) 922-129<br>contact@nabertherm.de<br>www.nabertherm.com<br>Made in Germany |   |   |
| ①  | ② | ④ |
| ③  |   |   |
|  |   |   |
|   |   |   |

- ① Furnace model
- ② Serial number
- ③ Article number
- ④ Year of construction

Fig. 58: Example (type plate)

## 13 Shut-Down, Dismantling, and Storage

### 13.1 Environmental Regulations

When it is delivered, this furnace contains no substances that make a hazardous waste classification necessary. However, residues of process materials may accumulate in the furnace insulation during operation. These may be hazardous to health and/or the environment.

- Dismantle the electronic components and dispose of them as electric scrap.
- Remove the insulation and dispose of it as hazardous waste (see “Servicing, Cleaning, and Maintenance with Ceramic Fiber Material”).
- Dispose of the housing as scrap metal.
- Contact the responsible disposal company to dispose of the materials listed above.



#### Safety information:

When the furnace is being disposed of, the lid lock should be destroyed. This stops children being locked in and facing the risk of death.

Separate the power cable and dispose of this together with the plug.



#### Note

Observe the national regulations of the country in which the furnace will be used.

## 13.2 Transportation/Return Transportation

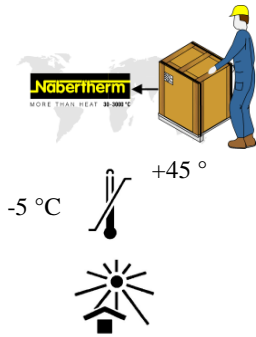

**If you still have the original packaging, this is the safest way to send a furnace.**

Otherwise:

Choose suitable, adequately sturdy packaging. During transportation, packages are often stacked, bumped, or dropped; the packaging acts as external protection for your furnace.

- **Drain all piping and containers before transportation/return transportation (e.g. cooling water). Pump off operating materials and dispose of properly.**
- **Do not subject the furnace to extreme cold or hot temperatures (direct sunlight)**
- **Storage temperature -5 °C to 45 ° (23 °F to 113 °F)**
- **Humidity 5 % to 80 %, non-condensing**
- **Place the furnace on a level floor to prevent distortion**
- **Packaging and transportation may be carried out only by qualified and authorized persons**

If your furnace has transportation securing equipment (see "Transportation Securing"), use this.

Otherwise, in general:

“Fix” and “secure” (adhesive tape) all moving parts and cushion and protect any projecting parts against breakage.

Protect your electronic equipment against moisture and make sure that no loose packaging material can get inside it.

Fill gaps in your packaging with soft but adequately firm material (e.g. foam mats) and make sure that the equipment cannot slide around in the packaging.

**If the goods are damaged during return transportation due to inadequate packaging or some other breach of duty, the costs will be borne by the customer.**

As a rule:

The furnace is sent without accessories, unless the technician expressly requests them.

Enclose a detailed description of the malfunction along with the furnace – this saves the technician time and costs.

Don't forget to enclose the name and phone number of a contact in case there are any questions.



**Note**

Return transportation may only be carried out according to the information given on the packaging or in the transportation documents.



**Note**

Transportation and return transportation **not** covered by a warranty claim are paid for by the customer.

## 14 Declaration of Conformity



### EC Declaration of Conformity

in accordance with EC directives 2014/35/EU,  
RoHS directives 2011/65/EU and  
EMC directive 2014/30/EU

Hereby

**Nabertherm GmbH**  
**Bahnhofstr. 20, 28865 Lilienthal, Germany**

declares that the product specified below conforms to the relevant fundamental safety and health requirements of the appropriate EU Directive both in its basic design and construction as well as in the version marketed by us. The declaration will cease to be valid if any modifications are made to the machine without our approval.

### Electrically heated chamber furnace

| Model | Top 16/R   | Top 45    | Top 45eco   | Top 45/R   | Top 60   |
|-------|------------|-----------|-------------|------------|----------|
|       | Top 60/R   | Top 60eco | Top 60/Leco | Top 80     | Top 100  |
|       | Top 100 LE | Top 130   | Top 140     | Top 140 LE | Top 160  |
|       | Top 190    | Top 220   | HO 70/L     | HO 70/R    | HO 100   |
|       | F 30       | F 75 L    | F 75        | F 110      | F 110 LE |
|       | F 220      |           |             |            |          |

For all furnaces with switchgear and controller

The following harmonized standards were applied:

- DIN EN 60335-1 (10.2012)
- DIN EN 61000-6-1 (10.2007), DIN EN 61000-6-3 (09.2011)

Lilienthal, 08.05.2017

  
\_\_\_\_\_  
Michael Oberschmidt  
Vice President R & D

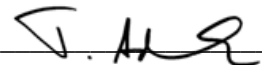
  
\_\_\_\_\_  
Thomas Adamek  
Head of Quality Management

## 15 For Your Notes

---

## For Your Notes

**For Your Notes**



MORE THAN HEAT 30-3000 °C

**Headquarters:**

Nabertherm GmbH · Bahnhofstr. 20 · 28865 Lilienthal/Bremen, Germany · Tel +49 (4298) 922-0, Fax -129 · [contact@nabertherm.de](mailto:contact@nabertherm.de) · [www.nabertherm.com](http://www.nabertherm.com)

Reg: M01.0062 ENGLISH